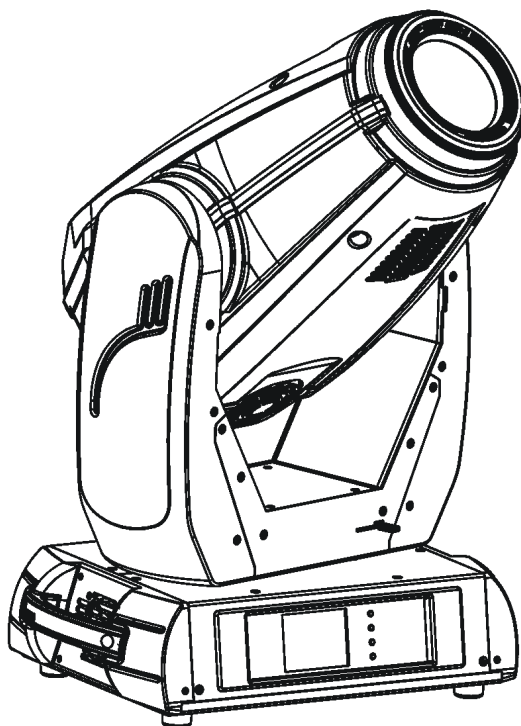

ROBE

ROBIN[®] DL4S

Profile

ROBIN[®] DL4S

**Profile Wireless DMX
CRMX[™]**



 **ROBIN[®]**
Innovative Technology

USER MANUAL

Version 1.3

ROBE[®] lighting s.r.o. • Czech Republic • www.robe.cz

Robin DL4S Profile

Table of contents

1. Safety instructions	3
2. Operating determination	4
3. Fixture exterior view	5
4. Installation	6
4.1 Connection to the mains	6
4.2 Replacing rotating gobos	7
4.3 Rigging the fixture	7
4.4 DMX-512 connection.....	9
4.5 Ethernet connection	10
4.6 Wireless DMX operation	12
5. Remotely controllable functions	13
6. Control menu map	15
7. Control menu	18
7.1 Tab "Address"	19
7.2 Tab "Information"	20
7.3 Tab "Personality"	22
7.4 Tab "Manual Control".....	23
7.5 Tab "Stand-alone"	24
7.6 Tab "Service"	25
8. RDM	28
9. Error and information messages	29
10. Technical Specifications	32
11. Maintenance and cleaning	33
12. Photometric diagrams	34

CAUTION!

***Keep this device away from rain and moisture!
Unplug mains lead before opening the housing!***

**FOR YOUR OWN SAFETY, PLEASE READ THIS USER MANUAL CAREFULLY
BEFORE YOU INITIAL START - UP!**

1. Safety instructions

Every person involved with installation and maintenance of this device have to:

- be qualified
- follow the instructions of this manual

CAUTION!

***Be careful with your operations.
With a high voltage you can suffer
a dangerous electric shock when touching the wires!***

This device has left our premises in absolutely perfect condition. In order to maintain this condition and to ensure a safe operation, it is absolutely necessary for the user to follow the safety instructions and warning notes written in this manual.

Important:

The manufacturer will not accept liability for any resulting damages caused by the non-observance of this manual or any unauthorized modification to the device.

Please consider that damages caused by manual modifications to the device are not subject to warranty.

Never let the power-cord come into contact with other cables! Handle the power cord and all connections with the mains with particular caution!

Make sure that the available voltage is not higher than stated on the rear panel.

WARNING! This unit does not contain an ON/OFF switch. Always disconnect power input cable to completely remove power from unit when not in use or before cleaning or servicing the unit.

Make sure that the power-cord is never crimped or damaged by sharp edges. Check the device and the power-cord from time to time.

Always disconnect from the mains, when the device is not in use or before cleaning it. Only handle the power-cord by the plug. Never pull out the plug by tugging the power cord.

This device falls under protection class I. Therefore it is essential to connect the yellow/green conductor to earth.

The electric connection, repairs and servicing must be carried out by a qualified employee.

Do not connect this device to a dimmer pack.

During the initial start-up some smoke or smell may arise. This is a normal process and does not necessarily mean that the device is defective.

Do not touch the device's housing bare hands during its operation (housing becomes hot)!
For replacement use fuses of same type and rating only.

**Warning! Risk Group 2 LED product according to EN 62471.
LED light emission. Risk of eye injury. Do not look into the beam at short distance of the of the product. Do not view the light output with optical instruments or any device that may concentrate the beam
The light source contains blue LEDs.**

2. Operating determination

This device is a moving head for creating decorative effects and was designed for indoor use only.

If the device has been exposed to drastic temperature fluctuation (e.g. after transportation), do not switch it on immediately. The arising condensation water might damage your device. Leave the device switched off until it has reached room temperature.

Do not shake the device. Avoid brute force when installing or operating the device.

Never lift the fixture by holding it at the projector-head, as the mechanics may be damaged. Always hold the fixture at the transport handles.

When choosing the installation-spot, please make sure that the device is not exposed to extreme heat, moisture or dust. There should not be any cables lying around. You endanger your own and the safety of others!

The minimum distance between light output and the illuminated surface must be more than 3 meters.

Make sure that the area below the installation place is blocked when rigging, derigging or servicing the fixture.

Always fix the fixture with an appropriate safety rope. Fix the safety rope at the correct holes only.

Only operate the fixture after having checked that the housing is firmly closed and all screws are tightly fastened.

The maximum ambient temperature 45°C must never be exceeded.

CAUTION!
***The lens has to be replaced when it is obviously damaged,
so that its function is impaired, e. g. due to cracks or deep scratches!***

Operate the device only after having familiarized with its functions. Do not permit operation by persons not qualified for operating the device. Most damages are the result of unprofessional operation!

Please use the original packaging if the device is to be transported.

Please consider that unauthorized modifications on the device are forbidden due to safety reasons!

If this device will be operated in any way different to the one described in this manual, the product may suffer damages and the guarantee becomes void. Furthermore, any other operation may lead to dangers like short-circuit, burns, electric shock, burns etc.

3. Fixture exterior view

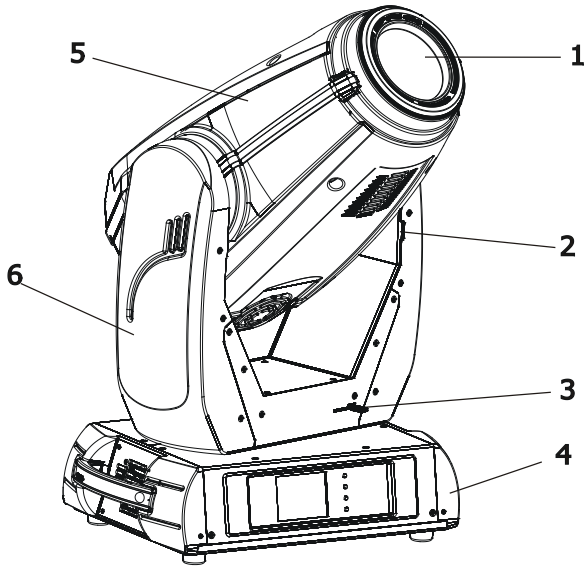

- 1 - Front lens
- 2 - Tilt lock
- 3 - Pan lock
- 4 - Base
- 5 - Moving head
- 6 - Arm

The head should be locked for transportation- the tilt lock latch (2) and the pan lock latch (3) have to be in the locked positions. To unlock the head, move these latches to unlock positions before operating the fixture.

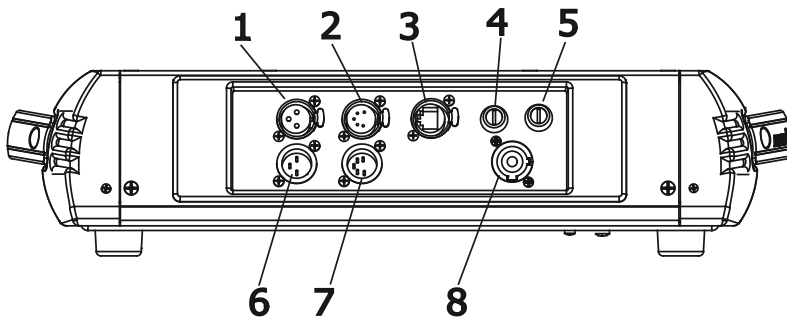

Rear panel of the base:

- 1 - 3-pin DMX output
- 2 - 5-pin DMX output
- 3 - Ethernet input-RJ45
- 4 - Fuse - live
- 5 - Fuse - neutral
- 6 - 3-pin DMX input
- 7 - 5-pin DMX input
- 8 - PowerCon

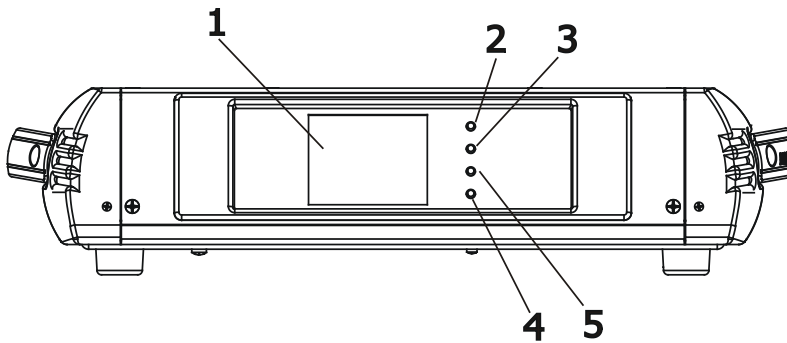

Front panel of the base:

- 1 - QVGA touch screen
- 2 - ESCAPE button
- 3 - NEXT button
- 4 - ENTER/DISPLAY ON button
- 5 - PREV button

The ENTER/DISPLAY ON button also serves for switching the display on when the fixture is disconnected from the mains.

4. Installation



Fixtures must be installed by a Qualified electrician in accordance with all national and local electrical and construction codes and regulation.

4.1 Connection to the mains

For protection from electric shock, the fixture must be earthed!

The Robin DL4S is equipped with auto-switching power supply that automatically adjusts to any 50-60Hz AC power source from 100-240 Volts.

Install a suitable plug on the power cord if needed, note that the cores in the power cord are coloured according to the following table. The earth has to be connected!

If you have any doubts about proper installation, consult a qualified electrician.

Core (EU)	Core (US)	Connection	Plug Terminal Marking
Brown	Black	Live	L
Light blue	White	Neutral	N
Yellow/Green	Green	Earth	

4.2 Replacing rotating gobos

DANGER!
Install the gobos with the device switched off only.
Unplug from mains before!

Rotating gobos

1. Disconnect the fixture from mains and allow it to cool.
2. Remove the bottom plastic cover of the head by loosening the 4 quarter-turn fasteners on the cover.
3. Gently pull up the gobo holder from the rotation gobo wheel.
4. Remove the spring gobo-lock with an appropriate tool (e.g. small-bladed screwdriver) and remove it.
Do not touch the surface of the pattern of the glass gobo.
5. Remove the original gobo and insert the new one (glazy side towards the light source). Insert the ring and the spring-gobo lock to secure it in the gobo holder.
6. Insert the gobo holder back under the distance slots into rotating gobo wheel.
5. Replace the bottom cover before applying power.

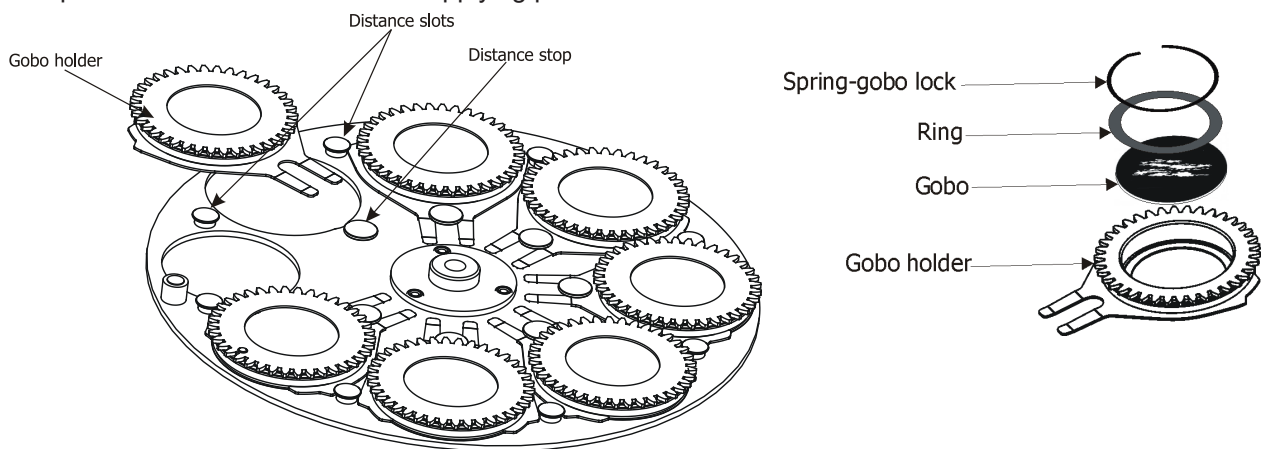

4.3 Rigging the fixture

The installation of the fixture has to be built and constructed in a way that it can hold 10 times the weight for 1 hour without any harming deformation.

The installation must always be secured with a secondary safety attachment, e.g. an appropriate catch net. This secondary safety attachment must be constructed in a way that no part of the installation can fall down if the main attachment fails.

When rigging, derigging or servicing the fixture staying in the area below the installation place, on bridges, under high working places and other endangered areas is forbidden.

The operator has to make sure that safety-relating and machine-technical installations are approved by an expert before taking into operation for the first time and after changes before taking into operation another time.

The operator has to make sure that safety-relating and machine-technical installations are approved by an expert after every four year in the course of an acceptance test.

The operator has to make sure that safety-relating and machine-technical installations are approved by a skilled person once a year.

The projector should be installed outside areas where persons may walk by or be seated.

IMPORTANT! OVERHEAD RIGGING REQUIRES EXTENSIVE EXPERIENCE, including (but not limited to) calculating working load limits, installation material being used, and periodic safety inspection of all installation

material and the fixture. If you lack these qualifications, do not attempt the installation yourself, but instead use a professional structural rigger. Improper installation can result in bodily injury or damage to property.

The fixture has to be installed out of the reach of people.

If the fixture shall be lowered from the ceiling or high joists, professional trussing systems have to be used. The fixture must never be fixed swinging freely in the room.

Caution: Fixtures may cause severe injuries when crashing down! If you have doubts concerning the safety of a possible installation, do not install the moving head!

Before rigging make sure that the installation area can hold a minimum point load of 10 times the fixture's weight.

Danger of fire !
When installing the device, make sure there is no highly inflammable material (decoration articles, etc.) in a distance of min. 0.5 m.

CAUTION!
Use 2 appropriate clamps to rig the fixture on the truss.
Follow the instructions mentioned at the bottom of the base.
Make sure that the device is fixed properly! Ensure that the structure (truss) to which you are attaching the fixtures is secure.

The fixture can be placed directly on the stage floor or rigged in any orientation on a truss without altering its operation characteristics .

For securing a fixture to the truss install a safety wire that can hold at least 10 times the weight of the fixture. Use only safety wire with screw-on carabine. Pull the safety wire through the carrying handles and around the truss as shown on the pictures below.

Note: If the safety wire is too long, whip it several times around the truss in order to attach the fixture tight. In case of an accident, the way of the falling fixture will be short.

Truss installation

1. Bolt each clamp (1) to the omega holder (3) with M12 bolt and lock nut through the hole in the holder.
2. Fasten the omega holders on the bottom of the base by inserting both quick-lock fasteners (4) into the holes of the base and tighten fully clockwise.
3. Pull the safety wire (2) through the carrying handles (5) and around the truss (6) as shown on the pictures below.

Securing the fixture via one safety wire

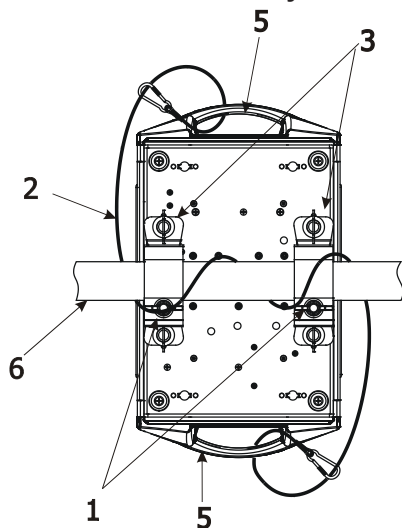

Securing the fixture via two safety wires

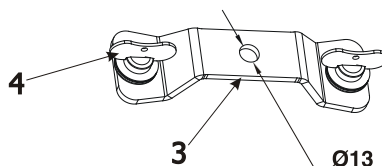
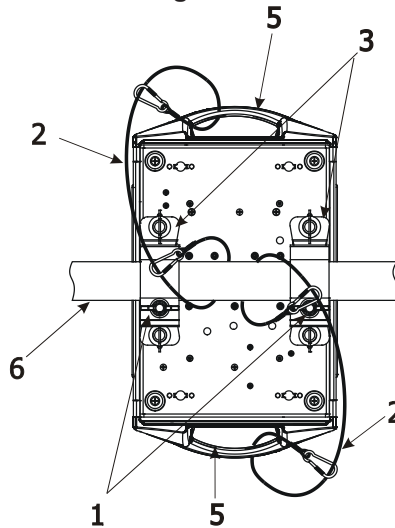

- 1-Clamps
- 2-Safety wire
- 3-Omega holder
- 4-Quick-lock fastener
- 5-Carrying handles
- 6-Truss

**When installing fixtures side-by-side,
avoid illuminating one fixture with another!**

DANGER TO LIFE!
**Before taking into operation for the first time, the installation has to be approved
by an expert!**

4.4 DMX-512 connection

The fixture is equipped with both 3-pin and 5-pin XLR sockets for DMX input and output. The sockets are wired in parallel.

Only use a shielded twisted-pair cable designed for RS-485 and 3-pin or 5-pin XLR-plugs and connectors in order to connect the controller with the fixture or one fixture with another.

DMX - output

XLR mounting-sockets (rear view):

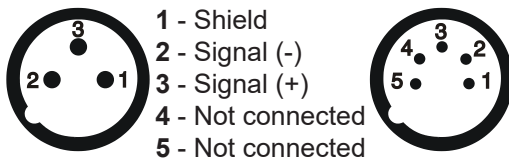

DMX-input

XLR mounting-plugs (rear view):

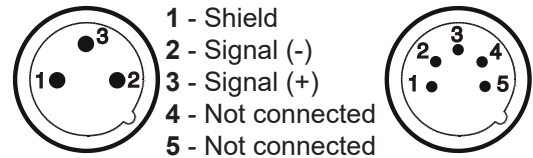

If you are using the standard DMX controllers, you can connect the DMX output of the controller directly with the DMX input of the first fixture in the DMX-chain. If you wish to connect DMX-controllers with other XLR-outputs, you need to use adapter-cables.

Building a serial DMX-chain:

Connect the DMX-output of the first fixture in the DMX-chain with the DMX-input of the next fixture. Always connect one output with the input of the next fixture until all fixtures are connected.

Caution: At the last fixture, the DMX-cable has to be terminated with a terminator. Solder a 120 Ω resistor between Signal (-) and Signal (+) into a 3-pin XLR-plug and plug it in the DMX-output of the last fixture.

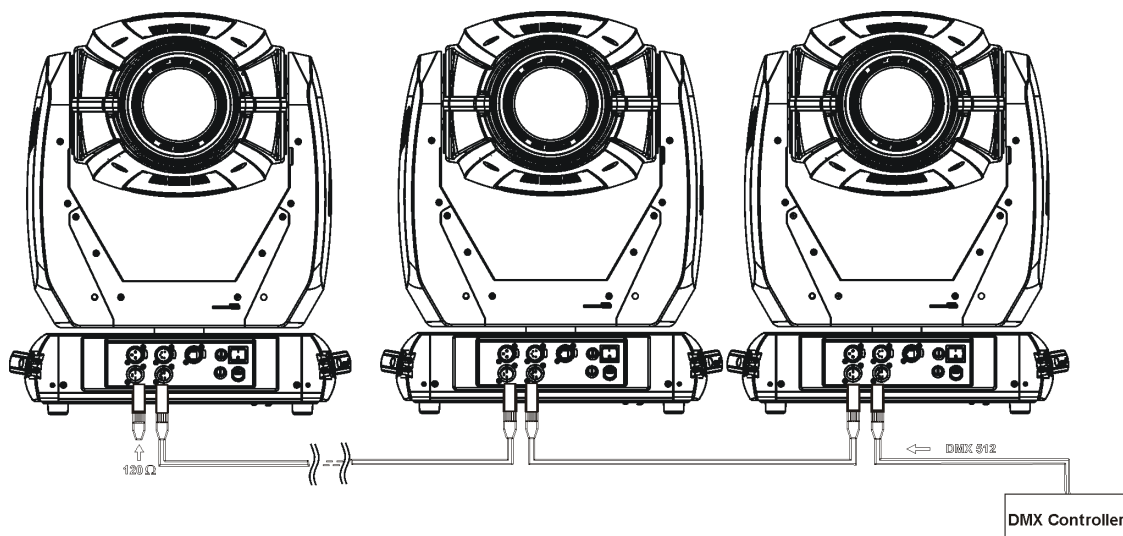

4.5 Ethernet connection

The fixtures on a data link are connected to the Ethernet with ArtNet communication protocol. The control software running on your PC (or light console) has to support Art-Net protocol.

Art-Net communication protocol is a 10 Base T Ethernet protocol based on the TCP/IP. Its purpose is to allow transfer of large amounts of DMX 512 data over a wide area using standard network technology.

IP address is the Internet protocol address. The IP uniquely identifies any node (fixture) on a network.

The Universe is a single DMX 512 frame of 512 channels.

The Robin DL4S is equipped with 8-pin RJ-45 socket for Ethernet input. Use a network cable category 5 (with four "twisted" wire pairs) and standard RJ-45 plugs in order to connect the fixture to the network.

RJ-45 socket (front view):

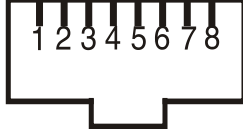

- | | |
|------------------|------------------|
| 1- TD+ | 5- Not connected |
| 2- TD- | 6- RX- |
| 3- RX+ | 7- Not connected |
| 4- Not connected | 8- Not connected |

RJ-45 plug (front view):

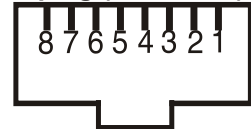

Patch cables that connect fixtures to the hubs or LAN sockets are wired 1:1, that is, pins with the same numbers are connected together:



If only the fixture and the computer are to be interconnected, no hubs or other active components are needed. A cross-cable has to be used:



If the fixture is connected with active Ethernet socket (e.g. switch) the network icon  will appear at the bottom right corner of the screen:

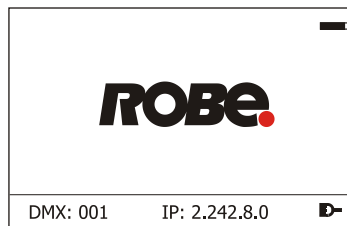

Direct Ethernet operation

Connect the Ethernet inputs of all fixtures with the Ethernet network.

Option "Artnet (gMal or gMA2)" has to be selected from "Ethernet Mode" menu on the fixture.

Set IP address (002.xxx.xxx.xxx / 010.xxx.xxx.xxx) and the Universe.

(DMX address=144)
IP address=002.168.002.004
Universe=1

(DMX address=48)
IP address=002.168.002.003
Universe=1

(DMX address=1)
IP address=002.168.002.002
Universe=1

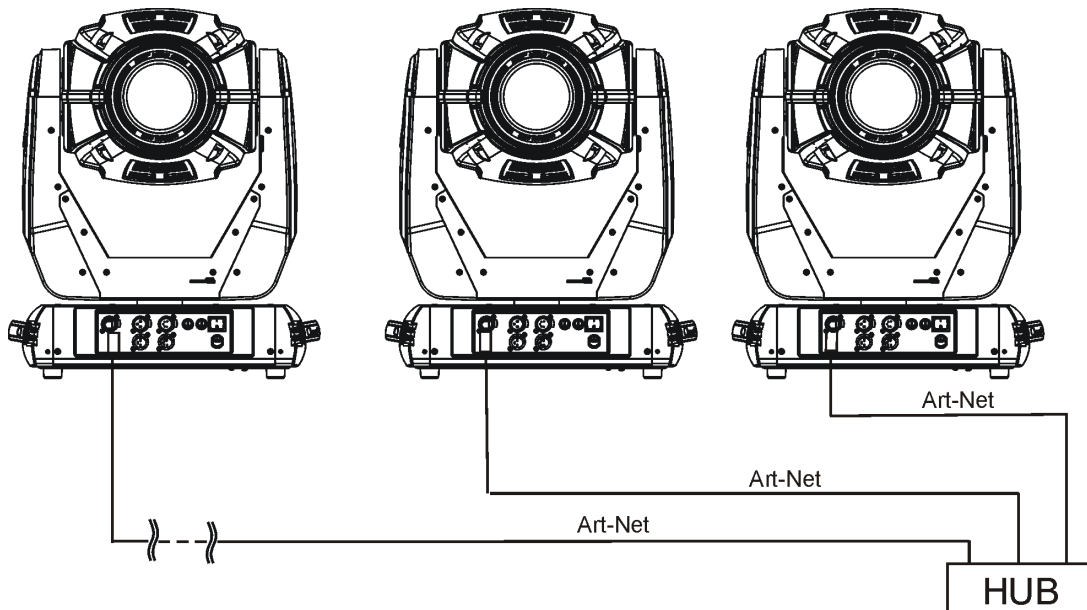

An advised PC setting: IP address: 002.xxx.xxx.xxx / 010.xxx.xxx.xxx (Different from fixture IP addresses)
NET mask: 255.0.0.0

Ethernet / DMX operation

Options "Art2DMX" has to be selected from the "Ethernet Mode" menu on the first fixture (connected to the Ethernet) in the fixture chain, next fixtures have standard DMX setting.

Connect the Ethernet-input of the first fixture in the data chain with the network. Connect the DMX output of this fixture with the input of the next fixture until all fixtures are connected to the DMX chain.

Caution: At the last fixture, the DMX chain has to be terminated with a terminator. Solder a 120 Ω resistor between Signal (-) and Signal (+) into a XLR-plug and connect it in the DMX-output of the last fixture.

Example:

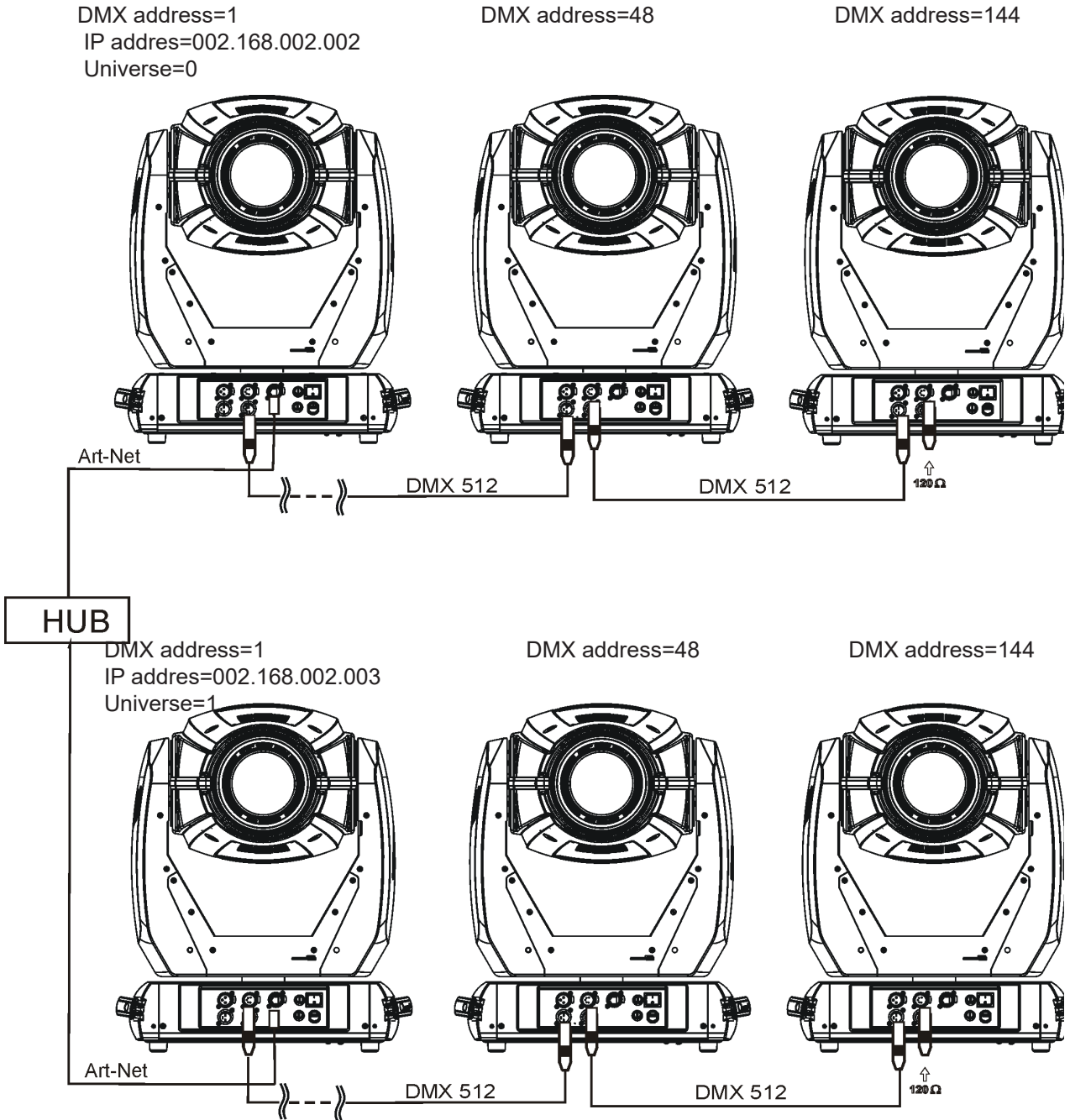

4.6 Wireless DMX operation

The wireless version of the Robin DL4S Spot is equipped with the Lumen Radio CRMX module and antenna for receiving DMX signal. CRMX module operates on the 2.4 GHz band.

The item " Wireless " from the menu "DMX Input" allows you to activate receiving of wireless DMX (Personality--> DMX Input -->Wireless.). First two options from the "DMX Input" menu are stated in DMX chart as well (channel Power/Special functions , range of 10-19 DMX). If DMX input option is changed by DMX command, the change is permanently written into fixture's memory.

DMX range of 10-19 switching fixture to the wired/wireless operation is active only during first 10 seconds after switching the fixture on.

After switching the fixture on, the fixture checks both modes of receiving DMX in the following order:

1. For the first five seconds, the fixture receives DMX signal from the wired input. If the Power/Special functions channel is set at some DMX input option, the fixture will receive DMX value according to this option. If DMX input option is set to the wired input , this option is saved and checking procedure is finished. If DMX input option is not set, the fixture continues next 5 seconds in scanning wireless DMX signal-see point 2.
2. For the next 5 seconds the fixture receives wireless DMX signal and again detects if the Power/Special functions channel is set at some DMX input option, if not, the fixture will take option which is set in the fixture menu "DMX Input".

To link the fixture with DMX transmitter.

The fixture can be only linked with the transmitter by running the link procedure at DMX transmitter . After linking , the level of DMX signal (0-100 %) is displayed in the menu item "Wireless State" (Information -->Wireless State).

To unlink the fixture from DMX transmitter.

The fixture can be unlinked from receiver via the menu item " Unlink Wireless Adapter" (Information--> Wireless State --> Unlink Wireless Adapter.).

Note: If the option "Wireless In/XLR Out" is selected (Personality--> DMX Input -->Wireless In/XLR Out), the fixture receives wireless DMX and sends the signal to its wired DMX output. The fixture behaves as " Wireless/ Wired" adapter.

Example:

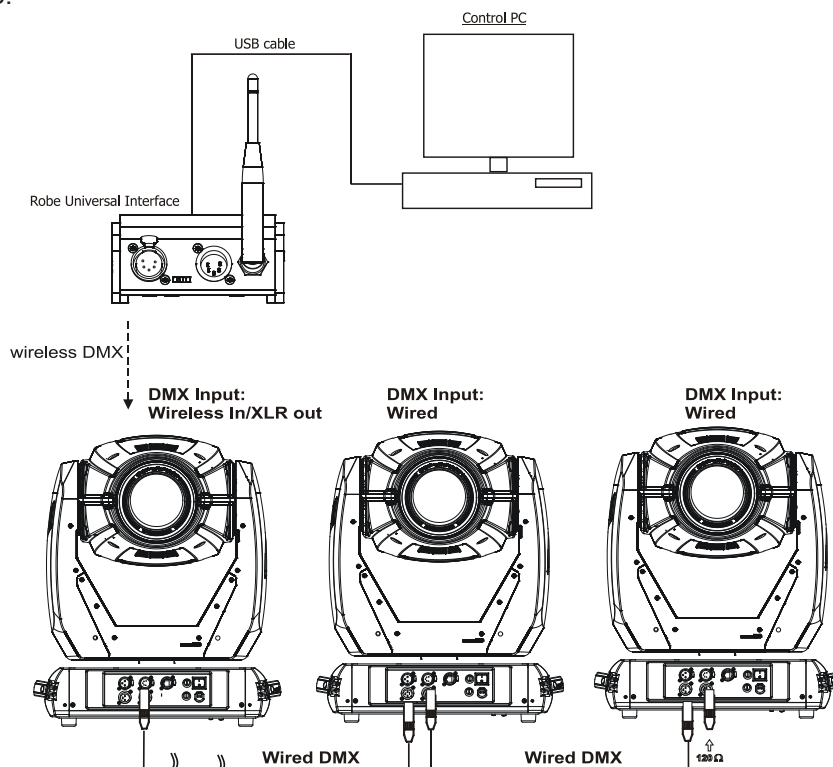

5. Remotely controllable functions

Virtual colour wheel

This wheel contains 236 colours including whites (2700K, 3200K, 4200K, 5600K and 8000K). Tungsten lamp effect at whites 2700K and 3200K.

RGBW or CMY colour mixing system

The RGBW colour mixing system is based on red, green, blue and white high power LEDs. Option for switching the fixture to the CMY colour mixing system is also available.

Effect wheel

The wheel rotates in both directions with variable speed which creates wide spectrum of graphic effects.

Rotating gobo wheel

The rotating gobo wheel includes 7 gobos rotating in both directions, indexable, replaceable "SLOT&LOCK" metal gobos + open position. Gobo positioning and gobo selection speed is available as well as a gobo-shake function.

Prism

The 3-facet prism rotates in both directions at different speeds, 16 prism/gobo macros are available.

Frost

Frost module provides variable frost for fine frosting.

Iris

Motorized adjustable iris, wide range of variable pulse effects.

Zoom

Motorized zoom unit enables zoom between 10 °- 45°.

Focus/Autofocus

Motorized focus allows to focus beam from approx. 2 meters to infinity.

Special function autofocus allows to keep focused image during zooming . Select desired distance and effect on which you need to focus at channel "Autofocus (priority & distance selection)" and use standard "Focus" channel to focus the image.

Pan & Tilt

Pan/Tilt movement ranges 0-540°/0-280°.

Dimmer/Shutter unit

Smooth 0 - 100 % dimming is provided by the electronic control unit. This unit is also used for strobe effects with variable speed.

Framing system

Framing system consists of four framing shutters . There is individual control of each shutter blade position and angle, together with rotation of the complete framing module. As well as providing a sharp precise or soft frame for the projected image, the system produces a new series of effects through pre-programmed shutter blade shape and movement sequences.

Framing shutters identification

Image on the wall

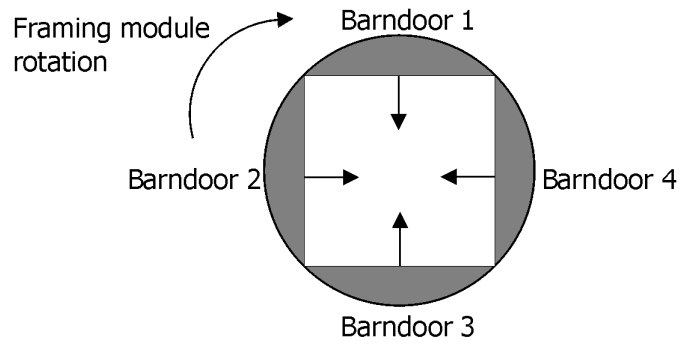

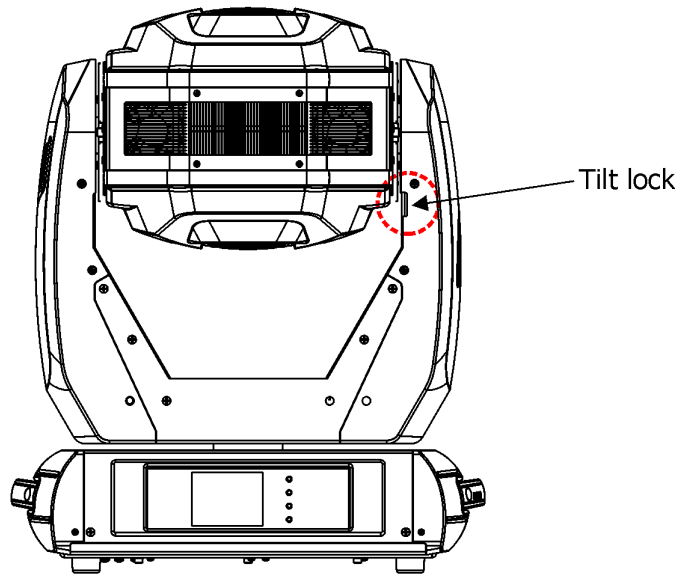

Head position







Pan = 85 DMX
Tilt = 45 DMX

6. Control menu map

Default settings=**Bold print**

Tab	Level 1	Level 2	Level 3	Level 4	Level 5	Level 6	
Addressing	Settings	DMX Address	001-512				
		Ethernet Settings	Ethernet Mode	Disable			
				ArtNet			
				gMA1			
				gMA2			
				sACN			
				Ethernet To DMX	Off, On		
				IP Address/Net Mask	Default IP Address		
					Custom IP Address		
					Net Mask		
				ArtNet Universe	0-255		
				MANet settings	MANet/II Universe	01-256	
					MANet Session ID	01-32	
				sACN Settings	sACN Universe	00001-32000	
					sACN Priority	0-255	
	Information	Fixture Times	Power On Time	Total Hours			
			Resetable Hours				
		LEDs On Time	Total Hours				
			Resetable Hours				
		Air Filters	Elapsed Time				
			Alert Period	10-300			
		Fixture Temperatures	LEDs Temperature	Current	R, GW, B		
				Maximum NonRes.	R, GW, B		
				Maximum Res.	R, GW, B		
			LEDs Board Temperature	Current			
				Maximum NonRes.			
				Maximum Res.			
			Ambient Temperature	Current			
				Maximum NonRes.			
				Maximum Res.			
			Base Temperature	Current			
			Maximum NonRes.				
			Maximum Res.				
	DMX Values	Pan					
		:					
		Dimmer Fine					
	Wireless State	Signal Quality					
		Unlink Wireless Adapter					
	Power Channel state	RGB Colour Mixing Mode					
		Pan/Tilt Speed Mode					
		Blackout if P/T Moves					
		Blackout if Gobo Moves					
	Software Versions	Display System					
		Module M					
		Module L-L					
		Module L-R					
		Module O					
		Module F-A					

Tab	Level 1	Level 2	Level 3	Level 4	Level 5	Level 6
		Module F-B				
		Module G				
	Product IDs	Mac Address				
		RDM UID				
		RDM Label				
	View Logs	Fixture Errors	Pan Errors			
			:			
			Temp.Sensor Errors			
		Fixture States	Power On			
			Power Off			
		Fixture Position				
		Fixture Temperatures	LED Temperatures			
			Ambient Temperatures			
			Base Temperatures			
Personality	User Mode	User A Settings				
		User B Settings				
		User C Settings				
	DMX Presets	Mode 1				
		Mode 2				
		Mode 3				
		View Selected Preset				
	DMX Input	Wired				
		Wireless				
		Wireless In/XLR Out				
	Pan/Tilt Settings	Pan Reverse	Off, On			
		Tilt Reverse	Off, On			
		Pan/Tilt Feedback	Off, On			
		Pan/Tilt mode	Time			
			Speed			
	Microphone Sensitivity	1-10-20				
	Blackout Settings	Blackout During M.C.	Off, On			
		Blackout while:	Pan/Tilt moving	Off, On		
			Gobo Wheels Moving	Off, On		
	Theatre Mode	Off				
		Auto				
		Silent	0-100%			
	Colour Calibration Mode	Off, On				
	Colour Mixing Mode	RGBW				
		CMY				
	White Point 8000K	On				
		Off				
	Colour Compatible Mode	On				
		Off				
	Init Effect Positions	Pan	0-255			
		:				
		Dimmer Fine	0-255			
	Screen Settings	Display Intensity	1-10			
		Screen Saver Delay	Off-10min.			
		Touchscreen Lock	Off-10min.			
		Recalibrate Touchscreen				

Tab	Level 1	Level 2	Level 3	Level 4	Level 5	Level 6
		Display Orientation	Normal			
			Inverted			
			Auto			
	Temperature Unit	°C, °F				
	Fan Mode	Auto				
		High				
	Dimmer Curve	Linear				
		Square law				
	Date & Time Settings					
	Unlink Wireless Adapter *					
	Default Settings					
Manual Control	Reset Functions	Reset All Systems				
		Pan/Tilt reset				
		Gobo System Reset				
		Optics/Prism/Frost Res.				
		Iris Reset				
	Preset Effect Control	Pan	Position 1-Position 5			
		:				
		Dimmer	Position 1- Position 5			
	Manual Effect Control	Pan	0-255			
		:				
		Dimmer Fine	0-255			
Stand -Alone	Test Sequences	Dynamic Mode				
		Static Mode	Pan	0-255		
			Tilt	0-255		
			Zoom	0-255		
			Focus	0-255		
	MusicTrigger	Off, On				
	Preset Playback	None				
		Test				
		Prg. 1				
		Prg. 2				
		Prg. 3				
	Play Program	Play Program 1				
		Play Program 2				
		Play Program 3				
	Edit Program	Edit Program 1	Start Step	1-100		
			End Step	1-100		
			Edit Program Steps	Step 1	Pan	0-255
				:	:	
				:	Dimmer Fine	0-255
				:	Step Time	0-25,5 sec.
				Step 100	Pan	0-255
					:	
					Dimmer Fine	0-255
					Step Time	0-25,5 sec.
Service	Adjust DMX Values	Pan	0-255			
		:				
		Dimmer Fine	0-255			
	Calibrations	Calibrate Effects	Pan	0-255		
			:			

Tab	Level 1	Level 2	Level 3	Level 4	Level 5	Level 6
			Focus	0-255		
		Calibrate colours	Red	0-255		
			Green	0-255		
			Blue	0-255		
		Load Default Calibrations				
	Update Software					

7. Control menu

The Robin DL4S Light is equipped with the QVGA Robe touch screen with battery backup which allows to set the fixture's behaviour according to your needs, obtain information on its operation, test its various parts and lastly program it, if it has to be used in a stand-alone mode. The fixture's menu can be controlled either by the control buttons or directly by touching the icon.

Control buttons on the front panel:

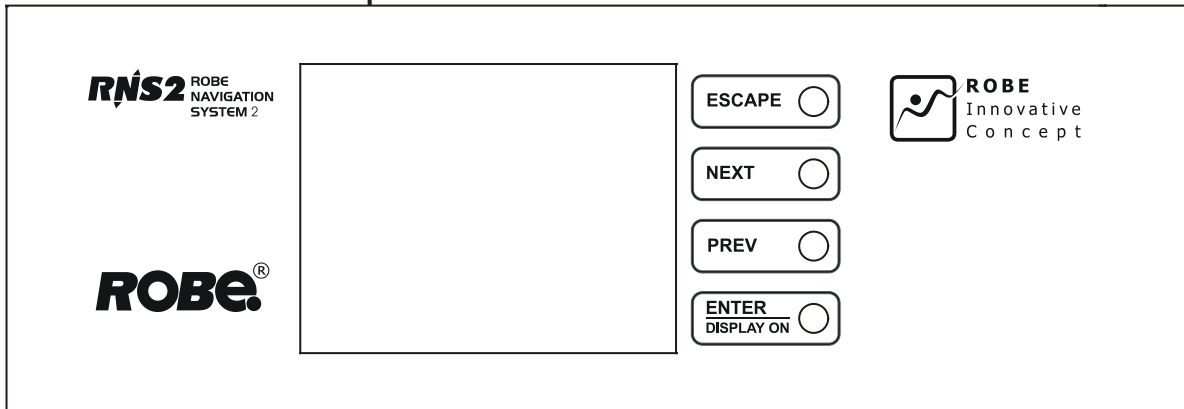

[ESCAPE] button used to leave the menu without saving changes.

[NEXT] , [PREV] buttons for moving between menu items and symbols, adjusting values.

[ENTER/Display On] button used to enter the selected menu (menu item) and to confirm adjusted value.

If the fixture is disconnected from mains, the button switches the touch screen on.

Icons used in the touch screen menu:



- [back arrow] used to move back to the previous screen (menu).



- [up arrow] used to move up on the previous page.



- [down arrow] used to move down on the next page.



- [confirm] used to save adjusted values, to leave menu or to perform desired action.



- [cancel] used to leave menu item without saving changes.



- [confirm+copy] used to save adjusted values and copy them to the next prog. step.



- [warning icon] used to indicate some error which has occurred in the fixture.



- [Ethernet] used to indicate Ethernet connected.



- [display turn] used to turn the display by 180°.

The menu page displays icons for each function that you can perform from the touch screen.

After switching the fixture on, the touch screen shows the screen with the ROBE logo:

Touch any part of the screen or press the [ENTER/Display On] button to display the initial screen with the current stored DMX address:

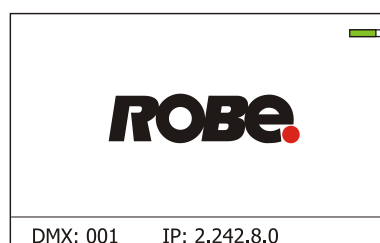

Note: The green icon at the top right corner of the screen indicates the level of the display battery charging. If the whole icon is green, the battery is fully charged while the red icon indicates exhausted battery. The battery charges during fixture operation, its charging lasts cca 6 hours.

We recommend that the fixture should be in operation at least 7 hours per week to keep the battery fully charged. If you switch the fixture on and this screen will not appear till 1 minute, switch the fixture off and on again. If the screen lights, the battery is exhausted. In case the screen still does not light, the battery is faulty.

This is also indicated by an error message "Faulty battery" and if such an error message appears the battery should be replaced immediately. The lifetime of the battery is highly dependent on ambient temperature (and consequently on base temperature). If the maximum ambient temperatures (as recorded and displayed in menu: Information -> Fixture Temperatures -> Ambient Temperature -> Maximum NonRes.) are kept within the specified limits, the battery should last for at least two years. Should the ambient temperatures exceed the specified maximum temperature, the lifetime of the batteries could be considerably shortened even up to just one year or less and also result in physical damage (battery leakage) or unreliable fixture functions.

Damage caused by batteries failed due to exceeded maximum ambient temperature cannot be claimed under warranty terms.

Touch the green arrow at the bottom right corner of the screen or press the [ENTER/Display On] button to enter the " Address" menu.

Each item (such as a Tab, menu item, text box, icon) may be selected from a screen by simply touching the

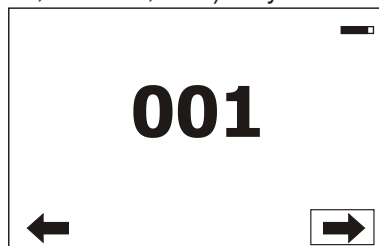

item in the list or by pressing the [NEXT] or [PREV] buttons to scroll through list items. With each press, the next item is highlighted. Press [ENTER/Display On] to select the highlighted item.

Before first fixture operation, set current date and time in the menu "Date &Time Settings" (menu path: Personality--> Date &Time Settings).

7.1 Tab " Address"



Settings - Select the menu to set desired fixture address setting.

DMX Address - Select the menu to set the DMX start address.

Ethernet Settings - The menu allows all needed settings for the Ethernet operation

Ethernet Mode

Disable - The option disables Ethernet operation.

Artnet - Fixture receives Artnet protocol

gMAI - Fixture receives MANet 1 protocol

gMA2 - Fixture receives MANet 2 protocol

sACN - Fixture receives sACN protocol

Ethernet To DMX - Fixture receives protocol from the Ethernet input and sends DMX data to its DMX output (fixture works as an "Ethernet/DMX converter", next fixture can be connected to its DMX output and you can build a standard DMX chain by connecting another fixtures. Only one fixture has to be connected to the Ethernet.

IP Address/Net Mask - Select this menu to set IP address. IP address is the Internet protocol address. The IP uniquely identifies any node (fixture) on a network.

There cannot be 2 fixtures with the same IP address on the network!

Default IP Address -Preset IP address, you can set up only first byte of IP address

(2 or 10) e.g. 002.019.052.086.

Custom IP Address - The option enables to set up all bytes of IP address.

Net Mask - The option enables to set up all bytes of Net Mask.

ArtNet Universe - Use this item to set a Universe (0-255). The Universe is a single DMX 512 frame of 512 channels.

MANet Settings - Use this menu to set parameters for MANet operation.

MANet Universe I/II - The value of this item can be set in range 1-256.

MANet Session ID - The value of this item can be set in range 1-32.

sACN Settings - Use this menu to set parameters for sACN operation.

sACN Universe - The value of this item can be set in range 1-32000.

sACN Priority - The value of this item can be set in range 0-255.

7.2 Tab "Information"



Fixture Times - The menu provides readouts of fixture and LED module operation hours.

Power On Time Hours - Select this menu to read the number of fixture operation hours.

Total Hours - The item shows the total number of the operation hours since the Robin DL4S has been fabricated.

Resetable Hours - The item shows the number of the operation hours that the Robin DL4S has been powered on since the counter was last reset.

In order to reset this counter to 0, touch the text box next to the item "Resetable Hours:"

LEDs On Time - Select this menu to read the number of LEDs operation hours for each colour (R,G,B,W).

In order to reset some counter to 0, touch the yellow text box next to desired colour.

Air Filters - Regular cleaning of the air filters is very important for the fixture's life and performance.

Build-up of dust, dirt and fog fluid residues reduces the fixture's light output and cooling ability.

The two items of this menu help you to keep cleaning period of the air filters.

Alert period - Cleaning schedule for the fixture depends on the operating environment.

It is therefore impossible to specify accurate cleaning interval. This item allows you to change the cleaning interval of the air filters. This "alert" value is 300 hours and it is set as default. Inspect the fixture within its 300 hours of operation to see whether cleaning is necessary. If cleaning is required, clean all air filters and change the value in this menu on acceptable level. Min. level of alert period is 10 hours, max. is 300 hours.

Elapsed Time - The item allows you to read the time which remains to cleaning air filters.

The time period is set in the menu mentioned above.

Expired time period is signalled by a negative mark (-) at the time value and a warning icon on the display.

Clean the filters and reset this menu item (by touching the text box next to the item "Elapsed Time").

Fixture Temperatures - The menu is used to view temperatures of the fixture's inside.

LEDs temperatures - The menu shows temperature on the LED PCBs (R-red LEDs, GW-green + white LEDs, B-blue LEDs).

Cur. - A current temperature of the LED PCB.

Max. - A maximum temperature of the LED PCB since the fixture has been fabricated.

Max. Res. - A maximum temperature of the LED PCB since the counter was last reset.

In order to reset some counter to 0, touch desired text box under item "Max.Res."

LEDs Board Temperature - The menu shows temperature in the fixture head on the LEDs control PCB.

Current - A current temperature on the LEDs control PCB.

Maximum NonRes. - A maximum temperature on the LEDs control PCB since the fixture has been fabricated.

Maximum Res. - A maximum temperature on the LEDs control PCB since the counter

was last reset.

In order to reset this counter to 0, touch the text box next to the item "Maximum Res."

Ambient Temperature - The menu shows temperature of the induced air on the fan in the fixture base .

Current - A current temperature of the induced air in the fixture base.

Maximum NonRes. - A maximum temperature of the induced air in the fixture base since the fixture has been fabricated.

Maximum Res. - A maximum temperature of the induced air in the fixture base since since the counter was last reset.

In order to reset this counter to 0, touch the text box next to the item "Maximum Res."

Base Temperature - The menu shows temperature in the fixture base (on the display PCB).

Current - A current temperature in the fixture base.

Maximum NonRes. - A maximum temperature in the fixture base since the fixture has been fabricated.

Maximum Res. - A maximum temperature in the fixture base since the counter was last reset.

In order to reset this counter to 0, touch the text box next to the item "Maximum Res."

DMX Values - The menu is used to read DMX values of each channel received by the fixture.

Wireless State - The menu serves for reading of the wireless operation status.

Unlink Wireless Adapter - The item serves for unlinking the fixture from the transmitter.

Power Channel State - Select this item to see current setting of the functions, which can be set by menu items in "Personality" as well as by DMX command at channel "Power/Special functions".

Software Version - Select this item to read the software version of the fixture modules:

Display System - A display processor on the display board in the fixture base

Module M - Pan/Tilt processor

Module L-L - LEDs control processor

Module L-R - LEDs control processor

Module O - Focus/zoom/prism/frost/ processor

Module F-A - Framming shutters processor

Module F-B - Framming shutters + Iris processor

Module G - Rot. gobo/Effect wheel processor

Product IDs - The menu is used to read the MAC Address ,RDM UID and RDM Label.

View Logs - Use this menu to read fixture's data which have been recorded during fixture operation. This collected data allows easier troubleshooting.

Fixture Errors - Use this menu to read fixture errors which have occurred during fixture operation.

There is a list of error folders:

Pan Errors

Tilt Errors

Dimmer 1 Errors

Dimmer 2 Errors

Colour Errors

Zoom Errors

Gobo Errors

Gobo Carousel Errors

Effect Wheel Errors

Iris Errors

Focus Errors

Prism Errors

Prism Rotation Errors

Frost Errors

Clean Air Filters

Overheated

Temp. Sensor Errors

Clean Air Filters

Fixture States - Recorded following actions: Fixture On, Fixture Off.

Fixture Position - Recorded installation positions of the fixture:

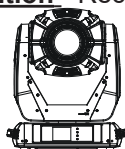

Disp-FN



Disp-FI

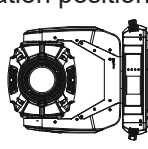

Disp-ST

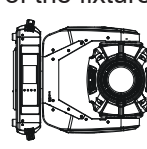

Disp-SB

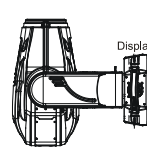

Disp-T

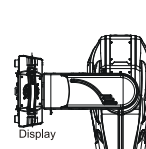

Disp-B

Fixture Temperatures - Recorded temperatures which have exceeded defined levels.

Note: The log buffer can contain 8000 records max. If the buffer is full, old data will be overwritten.

7.3 Tab "Personality"



User mode - The Robin DL4S allows you to recall up to 3 user settings. After switching the fixture on for the first time, the User A settings is active. Now all changes made in the "Personality" menu , "Addressing" menu and the "Music Trigger" and "Preset Playback" items from the "Stand-alone" menu are saved to the User A settings. If you now select the User B settings, from this moment the changes made in these menus will be saved to the User B settings. After switching the fixture off and on, the User B setting is active. In this way you may use the 3 fixture operating behaviours.

User A Settings - the function recalls the user A settings.

User B Settings - the function recalls the user B settings.

User C Settings - the function recalls the user C settings.

DMX Preset - Use the menu to select desired channel mode.

Mode 1 - 47 control channels

Mode 2 - 38 control channels

Mode 3 - 36 control channels

View Selected Preset - Use the menu to display channels included in the selected mode.

DMX Input- Use the menu to select mode of receiving DMX signal.

Wired - DMX signal is received by means of the standard DMX cable.

Wireless - DMX signal is received by means of the inbuilt wireless module.

Wireless In/XLR Out- the fixture receives wireless DMX and sends the signal to its wired DMX output.

The fixture behaves as " Wireless/Wired" adapter.

The options "Wired" and "Wireless" are also stated in DMX chart (channel Power/Special functions).

Pan/Tilt Settings - Use the menu set behaviour of both pan and tilt movements.

Pan Reverse - The item allows to invert pan movement.

Tilt Reverse - The item allows to invert tilt movement.

Pan/Tilt Feedback - The item allows to return the mowing head to the required pan/tilt position after changing the position by an external force if this option is set on.

Note. Be careful, the Pan/Tilt Feedback should be permanent On, the option Off is not suitable for standard operation and the head of the fixture can be damaged!

Pan/Tilt mode - Use this menu to set the mode of the pan/tilt movement

Time mode – The pan and tilt will move with different speeds and they will come at the same time to the end point of their tracks (pan and tilt use their optimal speeds).

Time of the pan/tilt movement (25.5 sec. max.) is set by the channel "Pan/Tilt speed, Pan/Tilt time".

Speed Mode - Both Pan and tilt will move with the same speed as adjusted at the channel "Pan/Tilt speed, Pan/Tilt time".

Microphone Sensitivity - Enter the menu if you want to adjust the microphone sensitivity from 1 (max.) to 20 (min.).

Blackout Settings - Use the menu if you need to close the light output under certain conditions which are described below

Blackout DMC - Blackout during movement correction. Set this option On if you wish to close light output during the time when the head goes to its correct position, which has been changed by an external force.

Active Blackouts - Use this menu if you wish to close the light output during effect changes.

Pan/Tilt Moving - The menu item enables to close light output while the pan/tilt coordinates are changing.

Gobo Wheel Moving - The menu item enables to close light output while the rot. gobo wheel or the static gobo wheel is moving.

Theatre Mode - The mode reduces noise of the fixture due to fine control of fans and reduced speed of pan/tilt movement and gobo/prism rotation.

Off - The option is disabled

Auto - Automatic regulation of fans noise level.

Silent - After selecting this item, the option "Fan Noise Level" is accessible where desired level of the fans noise can be set.

Colour Calibration Mode - If the function is on, the white output from the fixture (and also mixed colours) is more uniform. Each colour is dynamically corrected according to the value set in the menu "Calibrate Effects" (Service-> Calibrations-> Calibrate Effects).

Colour Mixing Mode - This item allows switching into RGBW or CMY mode. In the CMY mode, the white(8bit)/white (16) bit channels are not active.

White Point 8000K - If the function is on, via the CTO channel you can set desired white in range of 8000K-2700K (0DMX-255DMX). Necessary condition is , that RGBW channels have to be full or set at the same DMX values. The CTO channel does not effect mixed colours except whites.
If you wish to "apply" CTO filter on mixed colours, set this menu item to Off.

Colour Compatible Mode - If this function is on, mixed colours are close to the Robin DLS Profile.

Init Effect Positions - Use the menu to set all effects to the desired positions at which they will stay after switching the fixture on without DMX signal connected.

Screen Settings - Use this menu to change the touch screen settings.

Display Intensity - The item allows to control the intensity of the screen (1-min., 10-max.).

Screen saver Delay - The item allows you to keep the screen on or to turn it off automatically after 1-10 minutes after last touch (or pressing any button on the control panel).

Touchscreen Lock - The item allows you to lock the screen after last touch (or pressing any button on the control panel). The time delay can be set in range of 1-10 minutes. To unlock the screen, press the [ENTER/Display On] button.

Recalibrate Touchscreen - The item starts calibration of the touchscreen. Follow the instructions on the screen.

Display Orientation - The menu allows to change display orientation.

Normal - Standard display orientation if the fixture is placed horizontally (e.g. on the ground).

Inverted - Inverted orientation (needed if the fixture is hanging on the truss).

Auto - The option activates a gravitation sensor for automatic screen orientation.

Note: **Auto** option is set as default. You change the display orientation by touching the icon  on the display, an the option set in the "Display Orientation" menu is temporarily overridden.

Temperature unit - Use the menu item to change temperature unit from °C to °F.

Fan Mode - Use the menu to set the fixture fans to max. power mode ("**High**") or to auto-control mode ("**Auto**").

Dimmer Curve - You can select desired dimmer curve: Linear or Square Law.

Date & Time Settings - Use this menu to set current date and time for the fixture log system (menu "View Logs"). Set this menu item before first fixture operation.

Default Settings - The menu item allows to set all fixture parameters in this menu to the default (factory) values except items "DMX Input" and "Theatre Mode".

7.4 Tab "Manual Control"



Reset Functions - The menu allows to reset the fixture either per function modules or all modules together.

Total Reset - The item resets all function modules.

Pan/Tilt Reset - The item resets a pan and tilt movement.

Gobo System Reset - The item resets a static/rotating gobo wheel.

Optics/Prism/Frost Res. - The item resets a zoom, focus, prism and a frost module.

Iris/Fr. Shutters Effect Wheel Reset - The item resets an iris module and framing shutters.

Preset Effect Control - Use the menu to show preset positions of each channel effect.

Manual Effect control - Use the menu to control all fixture channels by means of the control panel.

7.5 Tab "Stand-alone"



Test Sequences - Use the menu to run a test/demo sequences without an external controller, which will show you some possibilities of using Robin DL4S.

Dynamic Mode - This mode uses all Robin DL4S functions including pan/tilt movement and therefore is good for a complete introduction of the fixture.

Static Mode - This mode is suitable for projections on the wall, ceiling or ground without any pan/tilt movement. Adjust the pan, tilt, zoom and focus to desired positions and start test sequences by touching the green ► icon.

Music Trigger - Use the item to activate the sound control of the running program via the built-in microphone.

Preset Playback - This menu allows you to select the program which will be played in a loop after switching the fixture on (the option is commonly used in a stand-alone operation without an external controller).

None - The option disables "Presetting playback" function.

Test - The option starts the test sequences.

Prog. 1 - The option starts user program No. 1.

Prog. 2 - The option starts user program No. 2.

Prog. 3 - The option starts user program No. 3.

Play program - Use the menu to run desired program in a loop.

Play Program 1 - The option starts user program No.1.

Play Program 2 - The option starts user program No. 2.

Play Program 3 - The option starts user program No. 3.

Edit Program - Use the menu to create or to edit desired program. The Robin DL4S offers 3 free programs, each up to 100 steps.

Edit Program 1 - The option allows to edit user program No.1.

Edit Program 2 - The option allows to edit user program No.2.

Edit Program 3 - The option allows to edit user program No.3

To edit program:

1. Touch the item which you want to edit ("Edit Program 1" - "Edit Program 3").
2. Touch the item "Edit Program Steps".
3. Touch the item "Step 1".
4. From the list of effects touch desired effect and set its value. Browse through the list by touching the [up arrow] and [down arrow] and set all desired effects.
An item "Step Time" (value of 0-25.5 sec.) is the time during which effects last in the current step
5. Save adjusted effects to the current step by touching the [confirm] or save and copy them to the following step by touching the [confirm+copy]. By touching the text box "Preview" next to the current program step you can view created scene.
6. Repeat the steps 4 and 5 for next program steps.
7. After editing desired program steps, adjust the length of the program by touching the text boxes "Start Step" and "End Step".

Meaning of the icons used in the "Edit Program" menu:

- ⬇ - moves down on the next page
- ⬆ - moves up on the previous page
- ✓ - saves adjusted values and leaves menu
- ✓ + - saves values to the current step and copy them to the following prog. step

✗ - leaves menu without saving values

There is a chart describing behaviour of items "Pan/Tilt Macro" and "P./T. Macro Speed".

DMX	Pan/Tilt Macro
0 - 9	Disabled pan/tilt macro
10 - 31	Reserved
32 - 63	Figure of circle (from small to large)
64 - 95	Figure of horizontal eight (from small to large)
96 - 127	Figure of vertical eight (from small to large)
128 - 159	Figure of rectangle (from small to large)
160 - 191	Figure of triangle (from small to large)
192 - 223	Figure of star (from small to large)
224 - 255	Figure of cross (from small to large)
	Pan/Tilt Macro Speed
0	No macro generation
	Macro generation from fast to slow-forwards
	No macro generation
	Macro generation from slow to fast-backwards

7.6 Tab "Service"



Adjust DMX Values - The menu allows you to set all effects to desired positions before fine calibration of the effects .

Calibrations - This menu enables fine calibration of fixture effects and download default calibration values.

Calibrate Effects - The menu allows the fine adjustment of effects.

Pan- a pan position fine adjustment

Tilt - a tilt position fine adjustment

Effect Wheel - an effect wheel position fine adjustment

Rot. Gobo Wheel - a carousel of rotating gobos fine rotation

R. Gobo Index - a fine indexing of rotating gobo

Prism - a prism module fine adjustment

Iris - an iris module fine adjustment

Zoom - a zoom module fine adjustment

Focus - a focus module fine adjustment

Fr. Shutt.rot- a framing shutters modele fine rotation

Fr. Shutter I M1- a framing lamella 1 motor 1 -distance from stop

Fr. Shutter I M2- a framing lamella 1 motor 2 - distance from stop

Fr. Shutter 2 M1- a framing lamella 2 motor 1 - distance from stop

Fr. Shutter 2 M2- a framing lamella 2 motor 2 - distance from stop

Fr. Shutter 3 M1- a framing lamella 3 motor 1 - distance from stop

Fr. Shutter 3 M2- a framing lamella 3 motor 2 - distance from stop

Fr. Shutter 4 M1- a framing lamella 4 motor 1 - distance from stop

Fr. Shutter 4 M2- a framing lamella 4 motor 2 - distance from stop

Fr. Shutter 1 Mov. - a Fram. lamella 1 mowing

Fr. Shutter 1 Swiv. - a Fram. lamella 1 swivelling

Fr. Shutter 2 Mov. - a Fram. lamella 2 mowing

Fr. Shutter 2 Swiv.- a Fram. lamella 2 swivelling

Fr. Shutter 3 Mov. - a Fram. lamella 3 mowing

Fr. Shutter 3 Swiv. - a Fram. lamella 3 swivelling

Fr. Shutter 4 Mov. - a Fram. lamella 4 mowing

Fr. Shutter 4 Swiv. - a Fram. lamella 4 swivelling

Calibration of the effects via the control board

1. Disconnect DMX controller from the fixture and enter the "Calibrate Effects" menu.
2. Use the [up arrow] and [down arrow] to find "Pan" and touch it to enter the fine effect adjustment screen.
3. Set desired value and save it by touching the [confirm].
4. Repeat steps 2 and 3 for next item
5. After calibrating all effects, touch the [confirm] to save all adjusted values and reset the fixture.

Calibrate Colours - The menu serves for adjusting of LEDs saturation to achieve colour temperature of 5600K for white output.

- Red** - a red LEDs saturation fine adjustment
- Green** - a green LEDs saturation fine adjustment
- Blue** - a blue LEDs saturation fine adjustment
- White** - a white LEDs saturation fine adjustment

Calibration of the white colours via DMX controller

1. Connect DMX controller to the fixture, open shutter and dimmer, set zoom at 128 DMX, focus image and set the "Virtual Colour Wheel" channel at 8000K. Aim the light beam on the lux meter (e.g. Minolta CL-200 Chroma meter) which is placed at min distance of 2.5 from the fixture.
2. The channel "Power" has to be set at 240 DMX (disable theatre mode) and the channel "CTC" at 0 DMX.
3. Set the menu item "Colour Calibration Mode" to On (Personality-> Colour Calibration Mode-> On).
4. Enter the menu "Calibrate Colours".

For example, DMX mode 3 is set in the fixture.

5. Set the channel "Virtual Colour Wheel" (ch.5) at 8000K
6. Set the channel "White" (ch.66) from the calibration protocol at 255DMX and by means of the channels "Red", "Green", "Blue" (ch.63, 64,65) adjust the 8000K colour temperature as exactly as possible ($\Delta u'v' = \pm 0.0005$)
7. After adjusting of 8000K colour temperature, set the channel "CTC" (ch.10) at 1 for a few seconds until a light blink will appear. After that, set this channel back to 0 DMX.
8. Set the channel "Virtual Colour Wheel" (ch.5) at 4200K.
9. Set the channel "White" (ch.66) from the calibration protocol at 200 DMX and by means of the channels "Red", "Green", "Blue" (ch.63, 64,65) adjust the 4200K colour temperature as exactly as possible ($\Delta u'v' = \pm 0.0005$)
10. After adjusting of 4200K colour temperature, set the channel "CTC" (ch.10) at 1 for a few seconds until a light blink will appear. After that, set this channel back to 0 DMX.
11. Set the channel "Virtual Colour Wheel" (ch.5) at 3200K.
12. Set the channel "White" (ch.66) from the calibration protocol at 60 DMX and by means of the channels "Red", "Green", "Blue" (ch.63, 64,65) adjust the 3200K colour temperature as exactly as possible ($\Delta u'v' = \pm 0.0005$)
13. After adjusting of 3200K colour temperature, set the channel "CTC" (ch.10) at 1 for a few seconds until a light blink will appear. After that, set this channel back to 0 DMX.
14. Set the channel "Virtual Colour Wheel" (ch.5) at 2700K.
15. Set the channel "White" (ch.66) from the calibration protocol at 50 DMX and by means of the channels "Red", "Green", "Blue" (ch.63, 64,65) adjust the 2700K colour temperature as exactly as possible ($\Delta u'v' = \pm 0.0005$)
16. After adjusting of 2700K colour temperature, set the channel "CTC" (ch.10) at 1 for a few seconds until a light blink will appear. After that, set this channel back to 0 DMX.
17. Set the channel "Power" at 241 DMX (enable theatre mode).
18. Set the channel "Virtual Colour Wheel" (ch.5) at 8000K.
Set the channel "White" (ch.66) from the calibration protocol at cca 60 DMX and by means of the channels "Red", "Green", "Blue" (ch.63, 64,65) adjust the 8000K colour temperature as exactly as possible ($\Delta u'v' = \pm 0.0005$).
- Note: Sum of DMX values for green and white channel must be < 319 for correct operation of the Theatre Mode.
19. After adjusting of 8000K colour temperature, set the channel "CTC" (ch.5) at 1 for a few seconds until a light blink will appear. After that, set this channel back to 0 DMX.
20. Set the channel "Virtual Colour Wheel" (ch.5) at 5600K.
Set the channel "White" (ch.66) from the calibration protocol at cca 50 DMX and by means of the channels "Red", "Green", "Blue" (ch.63, 64,65) adjust the 5600K colour temperature as exactly as possible ($\Delta u'v' = \pm 0.0005$).
- Note: Sum of DMX values for green and white channel must be < 319 for correct operation of the Theatre Mode.
21. After adjusting of 5600K colour temperature, set the channel "CTC" (ch.10) at 1 for a few seconds until a light blink will appear. After that, set this channel back to 0 DMX.
22. Set the channel "Virtual Colour Wheel" (ch.5) at 4200K.
Set the channel "White" (ch.66) from the calibration protocol at cca 60 DMX and by means of the channels "Red", "Green", "Blue" (ch.63, 64,65) adjust the 5600K colour temperature as exactly as possible ($\Delta u'v' = \pm 0.0005$).
- Note: Sum of DMX values for green and white channel must be < 319 for correct operation of the Theatre Mode.
23. After adjusting of 4200K colour temperature, set the channel "CTC" (ch.10) at 1 for a few seconds until a light blink will appear. After that, set this channel back to 0 DMX.

24. Set the channel "Power" at 240 DMX (disable theatre mode).

25. Set the channel " Virtual Colour Wheel" (ch.5) at 5600K.

Set the channel "White" (ch.66) from the calibration protocol at 255 DMX and by means of the channels "Red", "Green", "Blue" (ch.63, 64,65) adjust the 5600K colour temperature as exactly as possible ($\Delta u'v' = +/-0.0005$).

26. After adjusting of 5600K colour temperature, touch  on fixture display to save adjusted values and reset the fixture.

Calibration protocol:

Effect	Mode 1	Mode 2	Mode 3
Pan	channel 48	channel 39	channel 37
Tilt	channel 49	channel 40	channel 38
Ef. wheel	channel 50	channel 41	channel 39
Rot. Gobo Wheel	channel 51	channel 42	channel 40
Rot. Gobo Index.	channel 52	channel 43	channel 41
Prism	channel 53	channel 44	channel 42
Iris	channel 54	channel 45	channel 43
Zoom	channel 55	channel 46	channel 44
Focus	channel 56	channel 47	channel 45
Fr. Shutters rot.	channel 57	channel 48	channel 46
Fr. Shutter I M1	channel 58	channel 49	channel 47
Fr. Shutter I M2	channel 59	channel 50	channel 48
Fr. Shutter 2 M1	channel 60	channel 51	channel 49
Fr. Shutter 2 M2	channel 61	channel 52	channel 50
Fr. Shutter 3 M1	channel 62	channel 53	channel 51
Fr. Shutter 3 M2	channel 63	channel 54	channel 52
Fr. Shutter 4 M1	channel 64	channel 55	channel 53
Fr. Shutter 4 M2	channel 65	channel 56	channel 54
Fr. Shutter 1 mov.	channel 66	channel 57	channel 55
Fr. Shutter 1 swiv.	channel 67	channel 58	channel 56
Fr. Shutter 2 mov.	channel 68	channel 59	channel 57
Fr. Shutter 2 swiv.	channel 69	channel 60	channel 58
Fr. Shutter 3 mov.	channel 70	channel 61	channel 59
Fr. Shutter 3 swiv.	channel 71	channel 62	channel 60
Fr. Shutter 4 mov.	channel 72	channel 63	channel 61
Fr. Shutter 4 swiv.	channel 73	channel 64	channel 62
Red	channel 74	channel 65	channel 63
Green	channel 75	channel 66	channel 64
Blue	channel 76	channel 67	channel 65
White	channel 77	channel 68	channel 66

Load Default Calibrations - The item loads default (factory) calibration values.

Updating software - The menu item allows you to update software in the fixture via either serial or USB port of PC.

The following are required in order to update software:

- PC running Windows 95/98/2000/XP or Linux
- DMX Software Uploader
- Flash cable RS232/DMX No.13050624 (if you want to use a serial port of PC)
- Robe Universal Interface (if you want to use an USB port of PC)

Note 1: Software update should execute a qualified person. If you lack qualification, do not attempt the update yourself and ask for help your ROBE distributor.

Note 2: DMX address, IP address, programs 1-3 and all items in the menu "Personality" will be set to their default (factory) values.

To update software in the fixture:

I. Installation of the DMX Software Uploader.

1. DMX Software Uploader program is available from the ROBE web site at WWW.robe.cz.
2. Make a new directory (e.g. Robe_Uploader) on your hard disk and download the software to it.
3. Unpack the program from the archive. If the Robe fixture is produced in both magnetic and electronic ballast version, name of DMX Software Uploader is the same for both versions.

II. Fixture software updating.

1. Determine which of your ports is available on your PC and connect it:
 - with the DMX input of the fixture if you using the flash cable RS232/DMX
 - with the DMX output of the Robe Universal Interface if you using the USB cable.
 Disconnect the fixture from the other fixtures in a DMX chain. Turn both the computer and the fixture on. Make sure the lamp is switched off (only if the fixture involves a lamp).
 2. Switch the fixture to the updating mode by touching the "Updating Software " item
 Note: If you do not want to continue in software update, you have to switch off and on the fixture to escape from this menu.

We recommend to cancel all running programs before starting the Software Uploader.
 3. Run the Software Uploader program. Select desired COM and then click on the Connect button. (Select COM if the serial port is used or DreamBox1 if the USB port is used).
 If the connection is OK, click on the "Start Uploading button" to start uploading. It will take several minutes to perform software update.

If the option "Incremental Update" is not checked, all processors will be updated (including processors with the same software version).

If you wish to update only later versions of processors, check the "Incremental Update box".

Avoid interrupting the process. Update status is being displayed in the Info Box window.

When the update is finished, the line with the text "The fixture is successfully updated" will appear in this window and the fixture will reset with the new software.

After updating, the fixture, calibration of the LED driver may start (it depends on software version before calibration).

8. RDM

This fixture supports RDM operation. RDM (Remote Device Management) is a bi-directional communications protocol for use in DMX512 control systems, it is the new open standard for DMX512 device configuration and status monitoring.

The RDM protocol allows data packets to be inserted into a DMX512 data stream without adversely affecting existing non-RDM equipment. By using a special „Start Code,“ and by complying with the timing specifications for DMX512, the RDM protocol allows a console or dedicated RDM controller to send commands to and receive messages from specific moving lights.

RDM allows explicit commands to be sent to a device and responses to be received from it.

The list of commands for Robin DL4S is the following.

Parameter ID	Discovery command	SET command	GET command
DISC_UNIQUE_BRANCH	*		
DISC_MUTE	*		
DISC_UN_MUTE	*		
DEVICE_INFO			*
SUPPORTED_PARAMETERS			*
SOFTWARE_VERSION_LABEL			*
DMX_START_ADDRESS		*	*
IDENTIFY_DEVICE		*	*
DEVICE_MODEL_DESCRIPTION			*
MANUFACTURER_LABEL			*
DEVICE_LABEL		*	*
SENSOR_DEFINITION			*
SENSOR_VALUE			*
DISPLAY_INVERT		*	*
DISPLAY_LEVEL		*	*
PAN_INVERT		*	*
TILT_INVERT		*	*
DEVICE_RESET		*	
DMX_PERSONALITY		*	*

DMX_PERSONALITY_DESCRIPTION			*
STATUS_MESSAGES			*
STATUS_ID_DESCRIPTION			*

¹...Another options for this command (only for Robe's fixtures):

value PARAMETER_DATA=0x84 - lamp OFF by DMX value on DMX channel

value PARAMETER_DATA=0x88 - lamp OFF if DMX is not present

²...Commands relative resetable values

9. Error and information messages

Occurred errors during fixture operation are signalled by the yellow warning icon at the bottom line of the screen:



Touch the warning icon or press the [ESCAPE] button to display error messages.

List of error and information messages:

Temper.Sensor Error

The message informs you that the communication between the head temperature sensor and the main processor failed..

Tilt Error 1 (Tilt Error 2)

This message will appear after the reset of the fixture if the head's magnetic-indexing circuit malfunctions (sensor failed or magnet is missing) or the stepping motor is defective or its driving IC on the PCB. The head is not located in the default position after the reset.

Pan Error 1 (Pan Error 2)

This message will appear after the reset of the fixture if the yoke's magnetic-indexing circuit malfunctions (sensor failed or magnet is missing) or the stepping motor is defective or its driving IC on the PCB. The yoke is not located in the default position after the reset of the fixture.

Prism Error 1 (Prism Error 2)

The messages will appear after the reset of the prism wheel if this wheel is not located in the default position.

Zoom Error 1 (Zoom Error 2)

The messages will appear after the reset of the zoom module if the zoom lens is not located in the default position.

Focus Error 1 (Focus Error 2)

The messages will appear after the reset of the focus module if the focus lens is not located in the default.

Gobo Carousel Error 1 (Gobo Carousel Error 2)

The messages will appear after the reset of the rotating gobo wheel if this wheel is not located in the default position.

Gobo rotation Error 1 (Gobo Rotation Error 2)

The messages will appear after the reset of the rotating gobo wheel if the rotating gobos are not located in the default positions.

Effect wheel Error 1 (Animation wheel Error 2)

The messages will appear after the reset of the static gobo wheel if this wheel is not located in the default position.

Clean Air Filters

The message informs that the item "Elapsed Time" in the "Fixture Information" menu is at 0 value. Clean air filters and reset this counter.

Red 1 Short Error/ Red 2 Short Error/ Red 3 Short Error/ Red 4 Short Error

Some red LEDs in the light source have short circuit or are disconnected.

Blue 1 Short Error/ Blue 2 Short Error/ Blue 3 Short Error/ Blue 4 Short Error

Some blue LEDs in the light source have short circuit or are disconnected.

Green 1 Short Error/ Green 2 Short Error/ Green 3 Short Error/ Green 4 Short Error

Some green LEDs in the light source have short circuit or are disconnected.

White 1 Short Error/ White 2 Short Error/ White 3 Short Error/ White 4 Short Error

Some white LEDs in the light source have short circuit or are disconnected.

10. Technical Specifications

Electrical

Power supply:.....electronic auto-ranging
Input voltage range:..... supply 100-240V, 50-60Hz
Live Fuse:.....T 8 A
Neutral Fuse:.....T 8 A
Max. power consumption* (RGBW=full):.....550W (power factor= 0.97; I=2.4A at 230V)

Optic

Light source: RGBW LED module
RGBW or CMY colour mixing +CTC
Min. LED life expectancy: 20.000 hours

Virtual colour wheel

237 colours including whites (2700K, 3200K, 4200K, 5600K and 8000K)
Halogen lamp effect at whites 2700K and 3200K
Rainbow effect with in both directions with variable speed

Effect wheel

Rotation in both directions with variable speed

Rotating gobo wheel

7 metal gobos can be indexed and rotated in both directions at different speeds
Gobo wheel continuous rotation
Metal gobos: outside diameter=26.9 mm, image diameter =22.5mm, thickness=0.15 mm, stainless steel
"Slot&lock" system for easy replacement of gobos
Gobos order:



Prism

Rotating 3-facet 11° prism with continuous rotation in both directions

Iris

Motorized iris for different beam diameters

Frost filter

Separate, variable frost filter

Framing shutters module

Four framing shutters can be moved or swivelled to desired position separately
Each framing shutter can move up to 80% of the beam and swivel +/- 25°
Complete framing shutters module can rotate +/- 45°
Smooth & Fast blade movements for creating mid-air effects, variable speed
Pre-programmed shape and blade sequence

Zoom

Linear motorized zoom
Min. beam angle :10° (gobo position)
Max. beam angle: 45°(free hole)

Strobe

Strobe effect with variable speed (0.3 - 20Hz)

Dimmer

Smooth dimmer from 0 - 100 %

Control

Graphic touch screen for fixture setting and addressing
Gravitation sensor for auto screen positioning
Battery backup of the touch screen
Readout fixture and LEDs usage, receiving DMX values, temperatures, etc
Built-in analyzer for easy fault finding, error messages
Built-in demo sequences
Black-out while head moving, colour or gobo changing
Silent fans cooling,
Stand-alone operation
3 user editable programs, each up to 100 steps
Supported protocols: USITT DMX 512, RDM, ArtNet, MANet, MANet2, sACN
Support of RDM (Remote Device Management)
3 DMX modes (47, 38, 36 control channels)

Wireless DMX/RDM module (only for Wireless DMX version)

Compliance with USITT DMX-512 (1986 & 1990) and 512-A
Full DMX fidelity and frame integrity
Auto sensing of DMX frame rate and frame size
<5ms DMX latency
Operational frequency range of 2402-2480 MHz
Producer: LumenRadio

Pan/Tilt

Pan movement range 540°
Tilt movement range 280°
16 bit movement resolution
Automatic Pan/Tilt position correction
Remotely controllable speed of pan/tilt movement for easy programming
Pan/tilt-lock mechanism

Connection

DMX data in/out: Locking 3-pin and 5-pin XLR
AC power input: Chassis connector Neutrik PowerCon, A-type, NAC3MPA
Cable connector Neutrik PowerCon, A-type, NAC3FCA, for power-in, (installed on the power cord)

Rigging

Mounting points: 2 pairs of 1/4-turn locks
Mounting horizontally or vertically via 2 Omega brackets

Temperatures

Maximum ambient temperature : 45° C
Maximum housing temperature : 90° C

Minimum distances

Min. distance from flammable surfaces: 0.5 m
Min. distance to lighted object: 2 m

Total heat dissipation

Maximum: 1770 BTU/hr

Weight (net)

22.7 kg

Dimensions (mm)

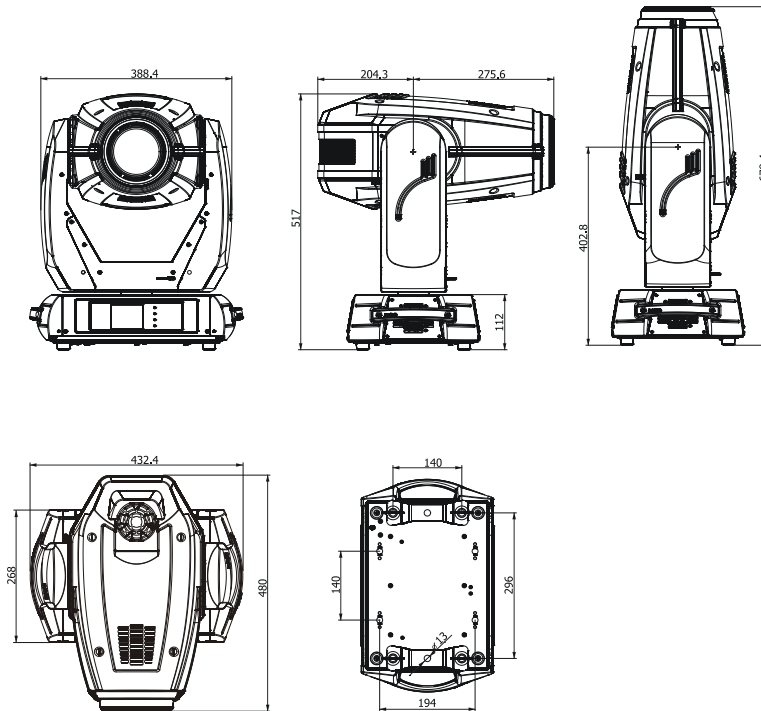

Accessories

- 1 x Omega adaptor CL-regular 2 pcs in box (P/N 10980033)
- 1 x Power cable
- 1 x Gobo set 16 (P/N.15050025)

Optional accessories

- Upgrade kit CRMX Univerzal 260 (P/N 9903 0100)
- Safety wire 35 kg (P/N 99011963)
- Doughty Trigger Clamp (P/N 17030386)

11. Maintenance and cleaning

It is absolutely essential that the fixture is kept clean and that dust, dirt and smoke-fluid residues must not build up on or within the fixture. Otherwise, the fixture's light-output will be significantly reduced. Regular cleaning will not only ensure the maximum light-output, but will also allow the fixture to function reliably throughout its life. A soft lint-free cloth moistened with any good glass cleaning fluid is recommended, under no circumstances should alcohol or solvents be used!

DANGER !
**Disconnect from the mains before starting any
maintenance work**

The front objective lens will require weekly cleaning as smoke-fluid tends to building up residues, reducing the light-output very quickly. The cooling-fans should be cleaned monthly.

The interior of the fixture should be cleaned at least annually using a vacuum-cleaner or an air-jet.

Gobo wheels and the internal lenses should be cleaned monthly.

Remove dust and dirt from the fans and cooling vents using a soft brush and vacuum-cleaner.

**Important! Check the air filters periodically and clean before they become
clogged!**

Clean the air filters placed in the fixture's covers and base. Use a vacuum cleaner, compressed air or you can wash them and put back dry.

After replacing the air filters, reset the elapsed time counter in the menu "Information" (Information--->Air Filters---> Elapsed Time).

Replacing the fuse

Before replacing the fuse, unplug mains lead.

- 1) Remove the fuse holder on the rear panel of the base with a fitting screwdriver from the housing (anti-clockwise).
- 2) Remove the old fuse from the fuse holder.
- 3) Install the new fuse in the fuse holder (only the same type and rating).
- 4) Replace the fuseholder in the housing and fix it.

12. Photometric diagrams

Beam angle 10° - Min. zoom

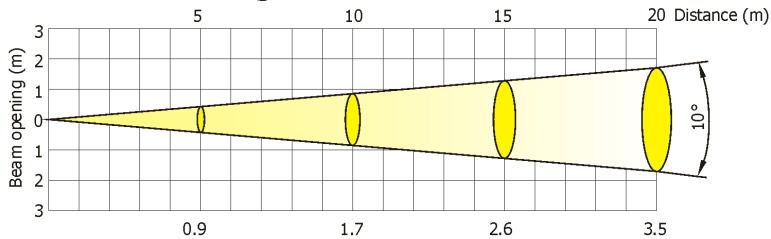

Distance (m)	5	6	8	10	12	14	15	20	
Red	2370/220	1645/153	925/55	593/55	412/38	302/28	263/25	148/14	Intensity (center) Lux/Footcandles
Green	5050/469	3507/326	1973/183	1263/117	877/82	644/60	561/52	315/29	
Blue	770/72	535/50	301/28	193/18	134/12	98/9	86/8	48/5	
White	3180/295	2208/205	1242/115	795/74	552/51	406/38	353/33	199/19	
R+G+B+W	11230/1043	7798/725	4387/407	2808/261	1950/181	1432/133	1248/116	700/65	

Beam angle 10° with frost

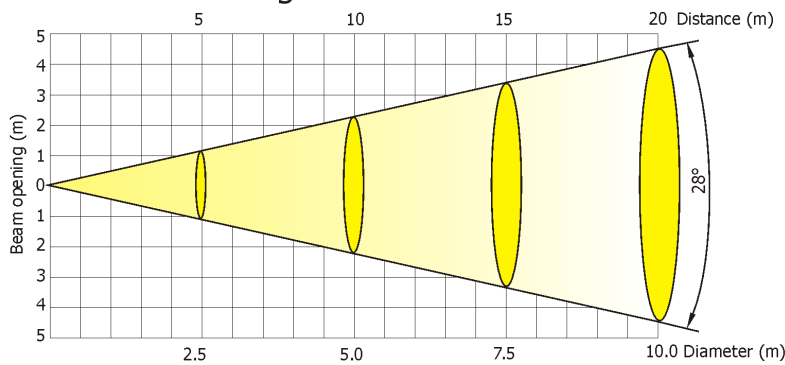

Distance (m)	5	6	8	10	12	14	15	20	
Red	279/26	194/18	109/10	70/6.5	48/4.5	36/3	31/3	17/1.6	Intensity (center) Lux/Footcandles
Green	638/59	443/41	249/23	160/15	111/10	81/8	71/7	40/3.7	
Blue	92/8.5	64/6	36/3.3	23/2	16/1.5	12/1	10/0.9	5/0.5	
White	441/41	306/28.5	172/16	110/10	77/7	56/5	49/5	28/2.6	
R+G+B+W	1440/134	1000/93	563/52	360/33.4	250/23	184/17	160/15	90/8.4	

Illuminance distribution

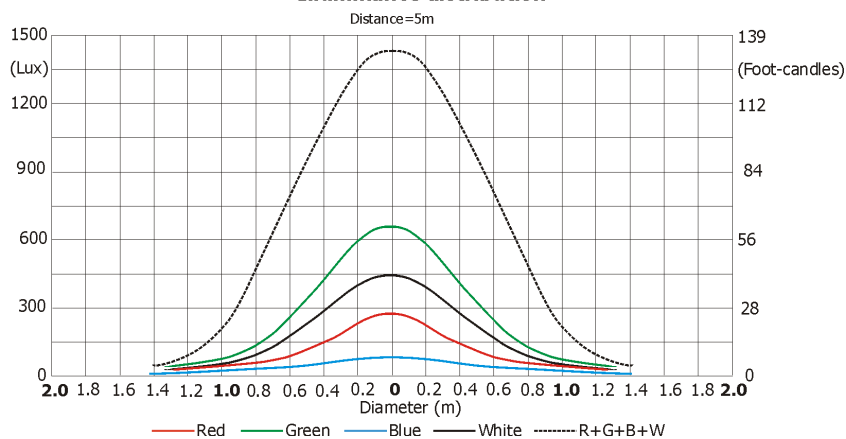

April 27, 2018

Copyright © 2016-2018 Robe Lighting - All rights reserved

All Specifications subject to change without notice

Made in CZECH REPUBLIC by ROBE LIGHTING s.r.o. Palackeho 416/20 CZ 75701 Valasske Mezirici

Beam angle 45° - Max. zoom

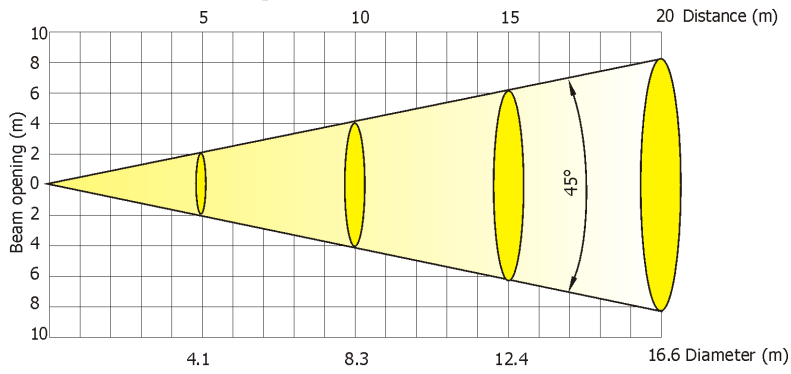

Distance (m)	5	6	8	10	12	14	15	20	
Red	226/21	157/15	88/8	57/5	39/4	29/2.7	25/2.3	14/1.3	Intensity (center) Lux/Footcandles
Green	490/45	333/31	188/17	120/11	83/8	61/6	53/5	30/2.8	
Blue	74/6.9	51/5	29/2.7	19/1.7	13/1.2	9/0.9	8/0.8	4.6/0.4	
White	450/42	313/29	176/16	113/11	78/7	57/5.3	50/4.6	28/2.6	
R+G+B+W	1235/115	857/80	482/45	309/29	214/20	158/15	137/13	77/7.2	

Beam angle 45° with frost

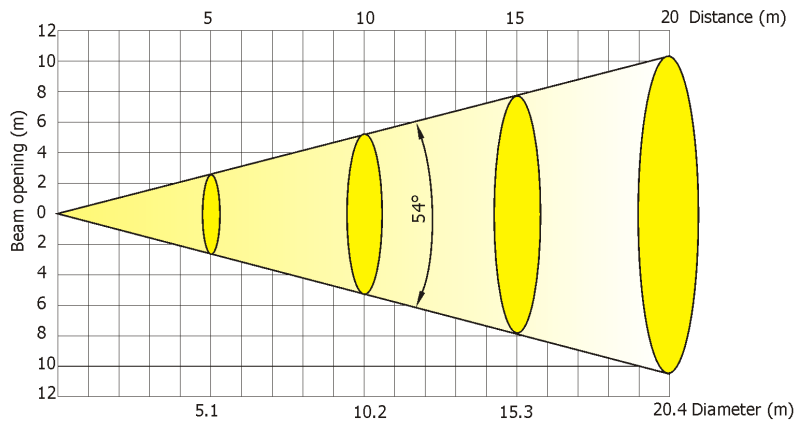

Distance (m)	5	6	8	10	12	14	15	20	
Red	73/7	51/4.7	29/2.6	18/1.7	12.7/1.2	9/0.9	8/0.8	4.6/0.4	Intensity (center) Lux/Footcandles
Green	112/10.4	78/7.2	44/4	28/2.6	19/1.8	14/1.3	12/1.2	7/0.7	
Blue	24/2.2	17/1.5	9/0.9	6/0.6	4.2/0.4	3.1/0.3	2.7/0.2	1.5/0.1	
White	128/12	89/8	50/4.6	32/3	22/2.1	16/1.5	14/1.3	8/0.7	
R+G+B+W	510/47	354/33	199/18.5	128/12	89/8	65/6	57/5.3	32/3	

Illuminance distribution

Distance=5m

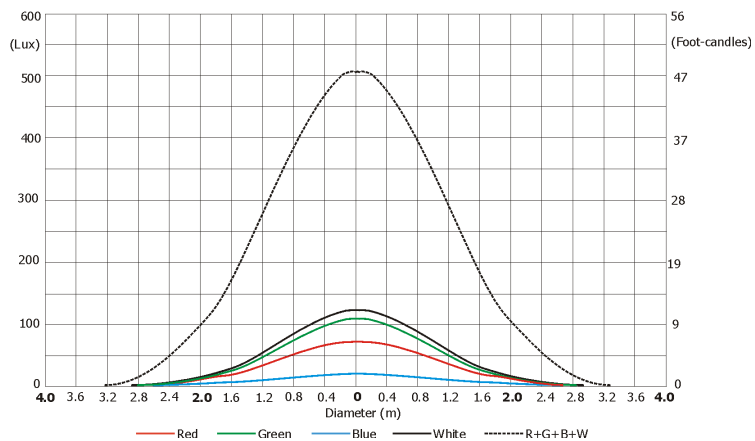

Robin DL4S Profile - DMX protocol - version 1.3

Mode/channel			DMX Value	Function	Type of control
1	2	3			
1	1	1	0 - 255	Pan Pan movement by 540°	proportional
2	2	*	0 - 255	Pan Fine Fine control of pan movement	proportional
3	3	2	0 - 255	Tilt Tilt movement by 280°	proportional
4	4	*	0 - 255	Tilt fine Fine control of tilt movement	proportional
5	5	3	0	Pan/Tilt speed , Pan/Tilt time Max. speed-Standard Mode (0=default)	step
			1 - 255	P./T. speed-set Speed Mode in menu: Pan/Tilt Mode Speed from max. to min.	proportional
			1 - 255	P./T. time - set Time Mode in menu: Pan/Tilt Mode Time from 0.1 s to 25.5 sec.	proportional
6	6	4	0 -9	Power/Special functions Reserved	
				<i>To activate following functions, stop in DMX value for at least 3 s and shutter must be closed at least 3 sec. („Shutter,Strobe“ channel 45/37/35 must be at range: 0-31 DMX). Corresponding menu items are temporarily overridden).</i>	
			10-14	DMX input: Wired DMX *	step
			15-19	DMX input: Wireless DMX *	step
				* function is active only 10 seconds after switching the fixture on	
			20-24	White point 8000K ON	step
			25-29	White point 8000K OFF	step
			30-39	RGB colour mixing mode	step
			40-49	CMY colour mixing mode	step
			50 - 59	Pan/Tilt speed mode	step
			60 - 69	Pan/Tilt time mode	step
			70 - 79	Blackout while pan/tilt moving	step
			80 - 89	Disabled blackout while pan/tilt moving	step
			90-94	DL Colour compatible mode On	step
			95-99	DL Colour compatible mode Off	step
			100-104	Dimmer curve: Square law	step
			105-109	Dimmer curve: Linear	step
			110 - 119	Blackout while gobo wheel moving	step
			120-129	Disabled blackout while gobo wheel moving	step
				<i>To activate following functions, stop in DMX value for at least 3 seconds.</i>	
			130 - 139	Fixture reset (except pan/tilt)	
			140 - 149	Pan/Tilt reset	step
			150 - 159	Reserved	step
			160 - 169	Gobo wheel reset	step
			170 - 179	Reserved	
			180 - 189	Zoom/focus/frost/prism reset	step
			190 - 199	Iris /framing shutters/effect wheel reset	step
			200 - 209	Total fixture reset	step

DMX protocol

Mode/channel			DMX Value	Function	Type of control
1	2	3			
			210-224	Reserved	
				The following RoboSpot related commands are only applicable when the RoboSpot is connected:	
			225 - 229	RoboSpot enabled	step
			230 - 234	RoboSpot disabled - except handle faders and pan/tilt	step
			235 - 239	RoboSpot fully disabled except pan/tilt	step
			240	Disable "Theatre mode"	step
			241	"Theatre mode" -automatic control of fan noise	step
			242 - 255	"Theatre mode" -fan noise control from min. to max.	proportional
7	7	5		Virtual colour wheel	
			0	No function	step
			1-2	White 2700 K	step
			3	White 2700 K (Halogen lamp mode**)	step
			4-5	White 3200 K	step
			6	White 3200 K (Halogen lamp mode**)	step
			7-9	White 4200 K	step
			10-12	White 5600 K	step
			13-15	White 8000 K	step
			16	Blue (Blue=full, Red+Green+White=0)	step
			17-55	Red=0, Green->up,Blue =full, White=0	proportional
			56	Light Blue (Red=0, Green=full, Blue =full, White=0)	step
			57 - 95	Red=0, Green=full, Blue->down, White=0	proportional
			96	Green (Red=0, Green=full, Blue =0, White=0)	step
			97 - 134	Red->up, Green=full, Blue=0, White=0	proportional
			135	Yellow (Red=full, Green=full, Blue=0, White=0)	step
			136 - 174	Red=full, Green->down, Blue=0, White=0	proportional
			175	Red(Red=full, Green=0, Blue=0, White=0)	step
			176 -214	Red=full, Green=0, Blue->up, White=0	proportional
			215	Magenta (Red=full, Green=0, Blue=full, White=0)	step
			216 - 246	Red -> down, Green=0, Blue=full, White=0	proportional
			247	Blue (Red=0, Green=0, Blue=full, White=0)	step
			248-251	Rainbow effect (with fade time)from slow-> fast	proportional
			252-255	Rainbow effect(without fade time) from slow-> fast	proportional
8	8	6		Red/Cyan (8 bit)***	
			0 - 255	Red or Cyan colour saturation control - coarse (0-100%)	proportional
9	*	*		Red/Cyan (16bit)***	
			0 - 255	Red or Cyan colour saturation control - fine	proportional
10	9	7		Green/Magenta (8 bit)***	
			0 - 255	Green or Magenta colour saturation control - coarse (0-100%)	proportional
11	*	*		Green/Magenta (16bit)***	
			0 - 255	Green or Magenta colour saturation control - fine	proportional
12	10	8		Blue/Yellow (8 bit)***	
			0 - 255	Blue or Yellow colour saturation control - coarse (0-100%)	proportional
13	*	*		Blue/ Yellow (16bit)***	
			0 - 255	Blue or Yellow colour saturation control - fine	proportional
14	11	9		White (8 bit)	
				If RGBW mode is selected:	
			0-255	White colour saturation control - coarse (0-100%)	proportional
				If CMY mode is selected:	
			0 - 255	No function	

DMX protocol

Mode/channel			DMX Value	Function	Type of control
1	2	3			
15	*	*	0 - 255	White (16 bit) White colour saturation control - fine (RGBW mode only)	proportional
16	12	10	0-255	CT0 <i>If function "White Point 8000K" is ON</i> Col. temperature correction from 8000K to 2700K -for whites only (0=8000K, 64=5600K, 128=4200K, 192=3200K,255=2700K) To get colour temperatures stated above, RGBW channels have to be set at the same value (e.g. 255DMX) or RGB=0 and White channel > 0 DMX <i>If function "White Point 8000K" is OFF</i> Colour temperature correction for mixed colours	proportional
17	13	11	0-255	Speed of rot. Gobo selection Speed of rot. gobo selection from max. to min. (0-25.5sec.)	proportional
18	14	12	0-19 20-127 128-170 171-213 214-255	Effect wheel positioning No function Proportional indexing (73-center) Ramping from open to full position (max--->min. speed) Ramping from open to half position (max. --->min. speed) Ramp. from half position to full position (max. --->min. speed)	step proportional proportional proportional proportional
19	15	13	0 1 - 127 128 - 129 130 - 255	Effect wheel rotation No rotation Forwards rotation from fast to slow No rotation Backwards rotation from slow to fast	step proportional step proportional
20	16	14	0-7 8-9 10-11 12-13 14-15 16-17 18-19 20-21 22-23 24-25 26-27 28-255	Effect wheel animations No animation Note : Set suitable DMX value at Focus channel to get desired animation. All animations were created at distance 7 m from screen with zoom=128DMX, Focus value is different for each effect (focus value is stated in parentheses for this distance) The channels are blocked: Effect wheel positioning, Effect wheel rotation Macro 1 (Focus=152) Macro 2 (Focus=113) Macro 3 (Focus=100) Macro 4 (Focus=105) Macro 5 (Focus=102) Macro 6 (Focus=110) Macro 7 (Focus=108) Macro 8 (Focus=121) Macro 9 (Focus=102) Macro 10 (Focus=98) Reserved	step step step step step step step step step step step
21	17	15	0-3 4-7 8-11	Rotating gobo wheel <i>In the range of 0-59 DMX the gobo selection speed is controlled by the Effect Speed channel.</i> Index - set indexing on channel 22/18/16 Open/hole Gobo 1 Gobo 2	step step step

DMX protocol

Mode/channel			DMX Value	Function	Type of control
1	2	3			
			12-15	Gobo 3	step
			16-19	Gobo 4	step
			20-23	Gobo 5	step
			24-27	Gobo 6	step
			28-31	Gobo 7	step
				<i>Rotation - set rotation on channel 22/18/16</i>	
			32-35	Gobo 1	step
			36-39	Gobo 2	step
			40-43	Gobo 3	step
			44-47	Gobo 4	step
			48-51	Gobo 5	step
			52-55	Gobo 6	step
			56-59	Gobo 7	step
				<i>Shaking gobos from slow to fast</i>	
				<i>Index - set indexing on channel 22/18/16</i>	
			60 - 69	Gobo 1	proportional
			70 - 79	Gobo 2	proportional
			80 - 89	Gobo 3	proportional
			90 - 99	Gobo 4	proportional
			100 - 109	Gobo 5	proportional
			110 - 119	Gobo 6	proportional
			120 - 129	Gobo 7	proportional
				<i>Shaking gobos from slow to fast</i>	
				<i>Rotation - set rotation on channel 22/18/16</i>	
			130 - 139	Gobo 1	proportional
			140 - 149	Gobo 2	proportional
			150 - 159	Gobo 3	proportional
			160 - 169	Gobo 4	proportional
			170 - 179	Gobo 5	proportional
			180 - 189	Gobo 6	proportional
			190 - 199	Gobo 7	proportional
			200 - 201	Open/hole	step
			202 - 221	Forwards gobo wheel rotation from fast to slow	proportional
			222 - 223	No rotation	step
			224 - 243	Backwards gobo wheel rotation from slow to fast	proportional
			244 - 249	Random gobo selection by audio control (Set microphone sensitivity in menu „Personality“)	step
			250 - 255	Auto random gobo selection from fast to slow	proportional
22	18	16		Rot. gobo indexing and rotation	
				<i>Gobo indexing - set position on channel 21/17/15</i>	
			0 - 255	Gobo indexing	proportional
				<i>Gobo rotation - set position on channel 21/17/15</i>	
			0	No rotation	step
			1 - 127	Forwards gobo rotation from fast to slow	proportional
			128 - 129	No rotation	step
			130 - 255	Backwards gobo rotation from slow to fast	proportional
23	*	*		Rot. gobo indexing/rotation - fine	
			0-255	Fine indexing (rotation)	proportional
24	19	17		Prism	

DMX protocol

Mode/channel			DMX Value	Function	Type of control
1	2	3			
			0 - 19	Open position (hole)	step
			20 - 127	3-facet rotating prism	step
			128 - 255	Prism/gobo macros	
			128 - 135	Macro 1	step
			136 - 143	Macro 2	step
			144 - 151	Macro 3	step
			152 - 159	Macro 4	step
			160 - 167	Macro 5	step
			168 - 175	Macro 6	step
			176 - 183	Macro 7	step
			184 - 191	Macro 8	step
			192 - 199	Macro 9	step
			200 - 207	Macro 10	step
			208 - 215	Macro 11	step
			216 - 223	Macro 12	step
			224 - 231	Macro 13	step
			232 - 239	Macro 14	step
			240 - 247	Macro 15	step
			248 - 255	Macro 16	step
25	20	18		Prism rotation	
			0	No rotation	step
			1 - 127	Forwards rotation from fast to slow	proportional
			128 - 129	No rotation	step
			130 - 255	Backwards rotation from slow to fast	proportional
26	21	19		Frost	
			0	Open	step
			1 - 179	Frost from 0% to 100%	proportional
			180 - 189	100% frost	step
			190 - 211	Pulse closing from slow to fast	proportional
			212 - 233	Pulse opening from fast to slow	proportional
			234 - 255	Ramping from fast to slow	proportional
27	22	20		Iris	
			0	Open	step
			1 - 179	From max.diameter to min.diameter	proportional
			180 - 191	Closed	step
				<i>Pulse effects with Iris blackout:</i>	
			192 - 219	Pulse opening from slow to fast	proportional
			220 - 247	Pulse closing from fast to slow	proportional
			248 - 249	Random pulse opening (fast)	step
			250 - 251	Random pulse opening (slow)	step
			252 - 253	Random pulse closing (fast)	step
			254 - 255	Random pulse closing (slow)	step
28	*	*		Iris - fine	
			0 - 255	Fine iris movement	proportional
29	23	21		Zoom	
			0 - 255	Zoom from max. to min.beam angle	proportional
30	*	*		Zoom - fine	
			0-255	Fine zooming	proportional
31	24	22		Focus	

DMX protocol

Mode/channel			DMX Value	Function	Type of control
1	2	3			
			0 - 255	Continuous adjustment from far to near	proportional
32	*	*		Focus - fine	
			0- 255	Fine focusing	proportional
33	25	23		Autofocus (priority & distance selection)	
				Select desired distance and effect on which you need to focus and use "Focus" channel (31/24/22) to focus the image.	
			0	Autofocus Off	step
				Hole and Framing shutters	
			1	4 metres	proportional
			8	6 metres	proportional
			16	8 metres	proportional
			24	10 metres	proportional
			32	12 metres	proportional
			40	14 metres	proportional
			48	16 metres	proportional
			56	18 metres	proportional
				Rotating gobo wheel	
			64	4 metres	proportional
			72	6 metres	proportional
			80	8 metres	proportional
			88	10 metres	proportional
			96	12 metres	proportional
			104	14 metres	proportional
			112	16 metres	proportional
			120	18 metres	proportional
			121-255	<i>Reserved</i>	
34	26	24		Framing shutters module rotation	
			0-127	Rotation from left to center	proportional
			128	Center	step
			129-255	Rotation from center to right	proportional
35	27	25		Framing shutter 1- movent	
			0-255	Movement from Outward to Inward	proportional
36	28	26		Framing shutter 1- swivelling	
			0-127	Swivelling from -25 degrees towards 0 degrees	proportional
			128	0 degrees (default)	step
			129-255	Swivelling from 0 degrees to +25 degrees	proportional
37	29	27		Framing shutter 2- movent	
			0-255	Movement from Outward to Inward	proportional
38	30	28		Framing shutter 2- swivelling	
			0-127	Swivelling from -25 degrees towards 0 degrees	proportional
			128	0 degrees (default)	step
			129-255	Swivelling from 0 degrees to +25 degrees	proportional
39	31	29		Framing shutter 3 movent	
			0-255	Movement from Outward to Inward	proportional
40	32	30		Framing shutter 3- swivelling	
			0-127	Swivelling from -25 degrees towards 0 degrees	proportional
			128	0 degrees (default)	step
			129-255	Swivelling from 0 degrees to +25 degrees	proportional
41	33	31		Framing shutter 4 movent	
			0-255	Movement from Outward to Inward	proportional

DMX protocol

Mode/channel			DMX Value	Function	Type of control
1	2	3			
42	34	32		Framing shutter 4- swivelling	
			0-127	Swivelling from -25 degrees towards 0 degrees	proportional
			128	0 degrees (default)	step
			129-255	Swivelling from 0 degrees to +25 degrees	proportional
43	35	33		Framing shutters macros	
			0-3	No function	
			4-7	Macro 1	step
			8-11	Macro 2	step
			12-15	Macro 3	step
			16-19	Macro 4	step
			20-23	Macro 5	step
			24-27	Macro 6	step
			28-31	Macro 7	step
			32-35	Macro 8	step
			36-39	Macro 9	step
			40-43	Macro 10	step
			44-47	Macro 11	step
			48-51	Macro 12	step
			52-55	Macro 13	step
			56-59	Macro 14	step
			60-63	Macro 15	step
			64-67	Macro 16	step
			68-71	Macro 17	step
			72-75	Macro 18	step
			76-79	Macro 19	step
			80-83	Macro 20	step
			84-87	Macro 21	step
			88-91	Macro 22	step
			92-95	Macro 23	step
			96-99	Macro 24	step
			100-103	Macro 25	step
			104-107	Macro 26	step
			108-111	Macro 27	step
			112-115	Macro 28	step
			116-119	Macro 29	step
			120-123	Macro 30	step
			124-127	Macro 31	step
			128-131	Macro 32	step
			132-135	Macro 33	step
			136-139	Macro 34	step
			140-143	Macro 35	step
			144-147	Macro 36	step
			148-151	Macro 37	step
			152-155	Macro 38	step
			156-159	Macro 39	step
			160-163	Macro 40	step
			164-167	Macro 41	step
			168-171	Macro 42	step
			172-175	Macro 43	step

DMX protocol

Mode/channel			DMX Value	Function	Type of control
1	2	3			
			176-179	Macro 44	step
			180-183	Macro 45	step
			184-187	Macro 46	step
			188-191	Macro 47	step
			192-195	Macro 48	step
			196-199	Macro 49	step
			200-203	Macro 50	step
			204-207	Macro 51	step
			208-211	Macro 52	step
			212-255	Reserved	
44	36	34		Framing shutters macro speed	
			0- 255	Speed from slow to fast.	proportional
45	37	35		Shutter/ strobe	
			0 - 31	Shutter closed	step
			32 - 63	Shutter open	step
			64 - 95	Strobe-effect from slow to fast	proportional
			96 - 127	Shutter open	step
			128 - 143	Opening pulse in sequences from slow to fast	proportional
			144 - 159	Closing pulse in sequences from fast to slow	proportional
			160 - 191	Shutter open	step
			192 - 223	Random strobe-effect from slow to fast	proportional
			224 - 255	Shutter open	step
46	38	36		Dimmer intensity	
			0 - 255	Dimmer intensity from 0% to 100%	proportional
47	*	*		Dimmer intensity - fine	
			0 - 255	Fine dimming	proportional
** In the Halogen lamp mode the Dimmer channel imitates behaviour of the halogen lamp during dimming					
*** Select RGB or CMY mixing mode on channel "Power/Special functions"					

Virtual colour wheel - colour mixing chart					
Scale*	Virtual Colour Wheel	Red	Green	Blue	White
	DMX	DMX	DMX	DMX	DMX
	Theatre mode off				
	1-3 (White 2700K)	255	176	8	20
	4-6 (White 3200K)	255	201	12	100
	7-9 (White 4200K)	249	243	28	200
	10-12 (White 5600K)	165	255	36	255
	13-15 (White 8000K)	172	255	65	255
	Theatre mode on				
	1-3 (White 2700K)	255	176	8	20
	4-6 (White 3200K)	255	201	12	100
	7-9 (White 4200K)	248	253	31	35
	10-12 (White 5600K)	209	255	46	63
	13-15 (White 8000K)	171	255	61	61
	16	0	0	255	0
	17	0	3	255	0
	18	0	6	255	0
	19	0	9	255	0
	20	0	12	255	0
	21	0	15	255	0
	22	0	18	255	0
	23	0	21	255	0
	24	0	24	255	0
	25	0	27	255	0
	26	0	30	255	0
	27	0	36	255	0
	28	0	41	255	0
	29	0	46	255	0
	30	0	52	255	0
	31	0	58	255	0
	32	0	64	255	0
	33	0	68	255	0
	34	0	74	255	0
	35	0	80	255	0
	36	0	86	255	0
	37	0	92	255	0
	38	0	98	255	0
	39	0	104	255	0
	40	0	110	255	0
	41	0	119	255	0
	42	0	129	255	0
	43	0	138	255	0
	44	0	147	255	0
	45	0	156	255	0
	46	0	165	255	0
	47	0	174	255	0
	48	0	183	255	0
	49	0	192	255	0
	50	0	201	255	0
	51	0	210	255	0
	52	0	219	255	0
	53	0	228	255	0
	54	0	237	255	0
	55	0	246	255	0
	56	0	255	255	0
	57	0	255	246	0
	58	0	255	237	0

Scale*	Virtual Colour Wheel	Red	Green	Blue	White
	DMX	DMX	DMX	DMX	DMX
	59	0	255	228	0
	60	0	255	219	0
	61	0	255	210	0
	62	0	255	201	0
	63	0	255	192	0
	64	0	255	183	0
	65	0	255	174	0
	66	0	255	165	0
	67	0	255	156	0
	68	0	255	147	0
	69	0	255	138	0
	70	0	255	129	0
	71	0	255	119	0
	72	0	255	110	0
	73	0	255	104	0
	74	0	255	98	0
	75	0	255	92	0
	76	0	255	86	0
	77	0	255	80	0
	78	0	255	74	0
	79	0	255	68	0
	80	0	255	64	0
	81	0	255	58	0
	82	0	255	52	0
	83	0	255	46	0
	84	0	255	41	0
	82	0	255	36	0
	86	0	255	30	0
	87	0	255	27	0
	88	0	255	24	0
	89	0	255	21	0
	90	0	255	18	0
	91	0	255	15	0
	92	0	255	12	0
	93	0	255	9	0
	94	0	255	6	0
	95	0	255	3	0
	96	0	255	0	0
	97	3	255	0	0
	98	6	255	0	0
	99	9	255	0	0
	100	12	255	0	0
	101	15	255	0	0
	102	18	255	0	0
	103	21	255	0	0
	104	24	255	0	0
	105	27	255	0	0
	106	30	255	0	0
	107	36	255	0	0
	108	41	255	0	0
	109	46	255	0	0
	110	52	255	0	0
	111	58	255	0	0
	112	64	255	0	0
	113	68	255	0	0
	114	74	255	0	0

Scale*	Virtual Colour Wheel	Red	Green	Blue	White
	DMX	DMX	DMX	DMX	DMX
	115	80	255	0	0
	116	86	255	0	0
	117	92	255	0	0
	118	98	255	0	0
	119	104	255	0	0
	120	110	255	0	0
	121	119	255	0	0
	122	129	255	0	0
	123	138	255	0	0
	124	147	255	0	0
	125	156	255	0	0
	126	165	255	0	0
	127	174	255	0	0
	128	183	255	0	0
	129	192	255	0	0
	130	201	255	0	0
	131	210	255	0	0
	132	219	255	0	0
	133	228	255	0	0
	134	240	255	0	0
	135	255	255	0	0
	136	255	246	0	0
	137	255	237	0	0
	138	255	228	0	0
	139	255	219	0	0
	140	255	210	0	0
	141	255	201	0	0
	142	255	192	0	0
	143	255	183	0	0
	144	255	174	0	0
	145	255	165	0	0
	146	255	156	0	0
	147	255	147	0	0
	148	255	138	0	0
	149	255	129	0	0
	150	255	119	0	0
	151	255	110	0	0
	152	255	104	0	0
	153	255	98	0	0
	154	255	92	0	0
	155	255	86	0	0
	156	255	80	0	0
	157	255	74	0	0
	158	255	68	0	0
	159	255	64	0	0
	160	255	58	0	0
	161	255	52	0	0
	162	255	46	0	0
	163	255	41	0	0
	164	255	36	0	0
	165	255	30	0	0
	166	255	27	0	0
	167	255	24	0	0
	168	255	21	0	0
	169	255	18	0	0
	170	255	15	0	0

Scale*	Virtual Colour Wheel	Red	Green	Blue	White
	DMX	DMX	DMX	DMX	DMX
	171	255	12	0	0
	172	255	9	0	0
	173	255	6	0	0
	174	255	3	0	0
	175	255	0	0	0
	176	255	0	3	0
	177	255	0	6	0
	178	255	0	9	0
	179	255	0	12	0
	180	255	0	15	0
	181	255	0	18	0
	182	255	0	21	0
	183	255	0	24	0
	184	255	0	27	0
	185	255	0	30	0
	186	255	0	36	0
	187	255	0	41	0
	188	255	0	46	0
	189	255	0	52	0
	190	255	0	58	0
	191	255	0	64	0
	192	255	0	68	0
	193	255	0	74	0
	194	255	0	80	0
	195	255	0	86	0
	196	255	0	92	0
	197	255	0	98	0
	198	255	0	104	0
	199	255	0	110	0
	200	255	0	119	0
	201	255	0	129	0
	202	255	0	138	0
	203	255	0	147	0
	204	255	0	156	0
	205	255	0	165	0
	206	255	0	174	0
	207	255	0	183	0
	208	255	0	192	0
	209	255	0	201	0
	210	255	0	210	0
	211	255	0	219	0
	212	255	0	228	0
	213	255	0	237	0
	214	255	0	246	0
	215	255	0	255	0
	216	246	0	255	0
	217	237	0	255	0
	218	228	0	255	0
	219	219	0	255	0
	220	210	0	255	0
	221	201	0	255	0
	222	192	0	255	0
	223	183	0	255	0
	224	174	0	255	0
	225	165	0	255	0
	226	156	0	255	0

Scale*	Virtual Colour Wheel	Red	Green	Blue	White
	DMX	DMX	DMX	DMX	DMX
	227	147	0	255	0
	228	138	0	255	0
	229	129	0	255	0
	230	119	0	255	0
	231	110	0	255	0
	232	104	0	255	0
	233	98	0	255	0
	234	91	0	255	0
	235	84	0	255	0
	236	77	0	255	0
	237	70	0	255	0
	238	63	0	255	0
	239	56	0	255	0
	240	49	0	255	0
	241	42	0	255	0
	242	35	0	255	0
	243	28	0	255	0
	244	21	0	255	0
	245	14	0	255	0
	246	7	0	255	0
	247	0	0	255	0
	248-255 (Rainbow effect)	****	****	****	****
* Colour scale as an illustration only					

